



www.grepool.com

EN INSTRUCTION MANUAL

Take the reference number of your pool into account when you do the assembly

PL INSTRUKCJA MONTAŻU

Podczas montażu należy wziąć pod uwagę numer referencyjny basenu.

CS POKYNY K MONTÁŽI

Take the reference number of your pool into account when you do the assembly

SK NÁVOD NA MONTÁŽ

Take the reference number of your pool into account when you do the assembly

RO MANUAL DE INSTRUCȚIUNI

Luăți în considerare numărul de referință al piscinei dvs. atunci când faceți asamblarea

SV MONTERINGSANVISNINGAR

Take the reference number of your pool into account when you do the assembly

KPCOR60

6,06 x 3,26 H 1,24m

KPCOR60L

6,06 x 3,26 H 1,24m



KPCOR46

4,66 x 3,26 H 1,24m



KPCOR28

3,26 x 3,26 H 0,96m



KPCOR2814

3,26 x 1,86 H 0,96m

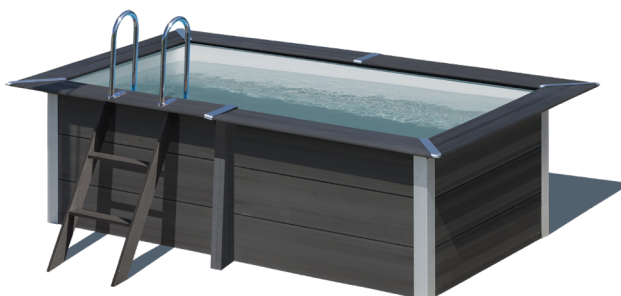

EN SUMMARY:

| | |
|------------------------------|----|
| 1 - SAFETY PRECAUTIONS. | 20 |
| 2 - COMPONENTS. | 23 |
| 3 - PREPARATION OF THE SITE. | 26 |
| 4 - INSTALLATION. | 37 |
| 5 - MAINTENANCE AND USE. | 63 |

PL SPIS TREŚCI:

| | |
|-------------------------------|----|
| 1 - ŚRODKI OSTROŻNOŚCI | 20 |
| 2 - ELEMENTY BASENU | 23 |
| 3 - PRZYGOTOWANIE TERENU | 26 |
| 4 - MONTAŻ | 37 |
| 5 - KONSERWACJA I UŻYTKOWANIE | 63 |

CS SUMMARY:

| | |
|------------------------------|----|
| 1 - SAFETY PRECAUTIONS. | 20 |
| 2 - COMPONENTS. | 23 |
| 3 - PREPARATION OF THE SITE. | 26 |
| 4 - INSTALLATION. | 37 |
| 5 - MAINTENANCE AND USE. | 63 |

SK SUMMARY:

| | |
|------------------------------|----|
| 1 - SAFETY PRECAUTIONS. | 20 |
| 2 - COMPONENTS. | 23 |
| 3 - PREPARATION OF THE SITE. | 26 |
| 4 - INSTALLATION. | 37 |
| 5 - MAINTENANCE AND USE. | 63 |

RO SUMAR:

| | |
|------------------------------|----|
| 1 - PRECAUȚII DE SIGURANȚĂ | 20 |
| 2 - COMPONENTE | 23 |
| 3 - PREGĂTIREA SITULUI | 26 |
| 4 - INSTALARE | 37 |
| 5 - ÎNTREȚINERE ȘI UTILIZARE | 63 |

SV SAMMANFATTNING:

| | |
|-------------------------------|----|
| 1 - SÄKERHETSÅTGÄRDER | 20 |
| 2 - KOMPONENTER. | 23 |
| 3 - FÖRBEREDELSE AV PLATSEN. | 26 |
| 4 - INSTALLATION. | 37 |
| 5 - UNDERHÅLL OCH ANVÄNDNING. | 63 |



EN IMPORTANT

- Read carefully the whole manual before mounting the pool.
- Before starting with the installation, extend all the pool components and check that they are the same as the ones on page 23.
- Handle with care all the swimming pool parts. They are very fragile and can be damaged easily.
- In case of failure to following these instructions, the warranty will be completely invalidated.
- If you have any questions, contact the technical service.

PL WAŻNE:

- Przed przystąpieniem do montażu basenu dokładnie zapoznaj się z całą instrukcją.
- Przed rozpoczęciem instalacji rozłóż wszystkie elementy basenu i sprawdź, czy są one takie same jak na stronie 23.
- Zachowaj ostrożność ze wszystkimi częściami basenu. Są one bardzo delikatne i mogą łatwo ulec uszkodzeniu.
- W przypadku nieprzestrzegania tych instrukcji, gwarancja zostanie całkowicie unieważniona.
- W razie jakichkolwiek pytań należy skontaktować się z serwisem technicznym.

CS IMPORTANT

- Read carefully the whole manual before mounting the pool.
- Before starting with the installation, extend all the pool components and check that they are the same as the ones on page 23.
- Handle with care all the swimming pool parts. They are very fragile and can be damaged easily.
- In case of failure to following these instructions, the warranty will be completely invalidated.
- If you have any questions, contact the technical service.

SK IMPORTANT

- Read carefully the whole manual before mounting the pool.
- Before starting with the installation, extend all the pool components and check that they are the same as the ones on page 23.
- Handle with care all the swimming pool parts. They are very fragile and can be damaged easily.
- In case of failure to following these instructions, the warranty will be completely invalidated.
- If you have any questions, contact the technical service.

RO IMPORTANT

- Citiți cu atenție întregul manual înainte de a monta piscina.
- Înainte de a începe cu instalarea, extindeți toate componentele piscinei și verificați dacă sunt aceleași cu cele de la pagina 23.
- Manipulați cu grijă toate părțile piscinei. Sunt foarte fragile și pot fi deteriorate cu ușurință.
- În cazul nerespectării acestor instrucțiuni, garanția va fi invalidată complet.
- Dacă aveți întrebări, contactați serviciul tehnic.

SV VIKTIGT

- Läs noga igenom hela handboken innan du monterar poolen.
- Innan du börjar med installationen, lägg ut alla poolkomponenterna och kontrollera att de är desamma som de på sidan 23.
- Hantera alla pooldelar försiktigt. De är mycket ömtåliga och kan lätt skadas.
- Om dessa instruktioner inte följs upphör garantin helt.
- Kontakta teknisk service om du har några frågor.

EN ATTENTION!

Carefully read this information and keep it for later consultations

Congratulations on your swimming pool choice. The model you have chosen has been especially designed for simple and rapid installation, but some precautions for safe handling and safe use are necessary. Before starting with the installation and assembly of your pool, consider the current local regulation about on ground and in ground pools.

The use of the pool kit includes respecting the safety instructions described in the maintenance and instructions for use manual. If the safety regulations are not respected, serious damages for your health and specially for children may occur. Read this manual carefully and pay attention to the illustrations before starting to assemble the pool. In the case of not following this manual for the pools assembly, in case of failure the guarantee may be rejected.

The information in this manual shows exactly how the pool should be assembled with illustrations that complement the assembly proces. Contractual elements such as illustrations may vary, regarding on shape, colour and aspect. Manufacturas Gre in its commitment to ongoing improvement of their products, reserves the right to modify at any time and without previous warning the features, the technical details, the standardized equipment and the different options of its products.

PL UWAGA!

Przeczytaj uważnie poniższe informacje i zachowaj je do wglądu w przyszłości.

Gratulujemy wyboru basenu. Model, który Państwo wybraliście został specjalnie zaprojektowany dla prostej i szybkiej instalacji. Nie mniej jednak należy zachować pewne środki ostrożności w celu jego bezpiecznej obsługi i użytkowania. Przed przystąpieniem do instalacji i montażu basenu należy zapoznać się z obowiązującymi lokalnymi przepisami dotyczącymi basenów naziemnych i podziemnych.

Podczas używania zestawu basenowego należy przestrzegać zasad bezpieczeństwa opisanych w instrukcji konserwacji i obsługi. Nieprzestrzeganie zasad bezpieczeństwa może doprowadzić do poważnych szkód dla zdrowia, a w szczególności dla zdrowia dzieci. Przed przystąpieniem do montażu basenu należy dokładnie przeczytać niniejszą instrukcję i zapoznać się z ilustracjami. W przypadku niestosowania się do instrukcji montażu basenu, w razie awarii, gwarancja może zostać odrzucona.

Informacje zawarte w niniejszej instrukcji dokładnie wyjaśniają, w jaki sposób basen powinien zostać zmontowany, a ilustracje uzupełniają instrukcje montażu. Rzeczywisty wygląd elementów składowych może różnić się pod względem kształtu, koloru i wyglądu od tych przedstawionych na ilustracjach. Manufacturas Gre, w ramach ciągłego doskonalenia swoich produktów, zastrzega sobie prawo do zmiany, w dowolnym momencie i bez uprzedzenia, wszelkich właściwości, szczegółów technicznych, wyposażenia standardowego i różnych opcji dotyczących swoich produktów.

CS ATTENTION!

Carefully read this information and keep it for later consultations

Congratulations on your swimming pool choice. The model you have chosen has been especially designed for simple and rapid installation, but some precautions for safe handling and safe use are necessary. Before starting with the installation and assembly of your pool, consider the current local regulation about on ground and in ground pools.

The use of the pool kit includes respecting the safety instructions described in the maintenance and instructions for use manual. If the safety regulations are not respected, serious damages for your health and specially for children may occur. Read this manual carefully and pay attention to the illustrations before starting to assemble the pool. In the case of not following this manual for the pools assembly, in case of failure the guarantee may be rejected.

The information in this manual shows exactly how the pool should be assembled with illustrations that complement the assembly proces. Contractual elements such as illustrations may vary, regarding on shape, colour and aspect. Manufacturas Gre in its commitment to ongoing improvement of their products, reserves the right to modify at any time and without previous warning the features, the technical details, the standardized equipment and the different options of its products.

SK ATTENTION!

Carefully read this information and keep it for later consultations

Congratulations on your swimming pool choice. The model you have chosen has been especially designed for simple and rapid installation, but some precautions for safe handling and safe use are necessary. Before starting with the installation and assembly of your pool, consider the current local regulation about on ground and in ground pools.

The use of the pool kit includes respecting the safety instructions described in the maintenance and instructions for use manual. If the safety regulations are not respected, serious damages for your health and specially for children may occur. Read this manual carefully and pay attention to the illustrations before starting to assemble the pool. In the case of not following this manual for the pools assembly, in case of failure the guarantee may be rejected.

The information in this manual shows exactly how the pool should be assembled with illustrations that complement the assembly proces. Contractual elements such as illustrations may vary, regarding on shape, colour and aspect. Manufacturas Gre in its commitment to ongoing improvement of their products, reserves the right to modify at any time and without previous warning the features, the technical details, the standardized equipment and the different options of its products.

RO ATENȚIE!

Citiți cu atenție aceste informații și păstrați-le pentru consultări ulterioare

Citiți cu atenție aceste informații și păstrați-le pentru consultări ulterioare

Felicitări pentru alegerea dvs. pentru piscină. Modelul pe care l-ați ales a fost special conceput pentru o instalare simplă și rapidă, dar sunt necesare câteva măsuri de precauție pentru manipularea și utilizarea în condiții de siguranță. Înainte de a începe cu instalarea și asamblarea piscinei dvs., luați în considerare reglementările locale actuale cu privire la sol și în bazinele din sol.

Utilizarea setului pentru piscină include respectarea instrucțiunilor de siguranță descrise în manualul de întreținere și instrucțiuni de utilizare. Dacă reglementările de siguranță nu sunt respectate, pot apărea daune grave pentru sănătatea dumneavoastră și în special pentru copii. Citiți cu atenție acest manual și acordați atenție ilustrațiilor înainte de a începe asamblarea piscinei. În cazul nerespectării acestui manual pentru asamblarea bazinelor, în caz de defecțiune, garanția poate fi respinsă.

Informațiile din acest manual arată exact cum ar trebui asamblat piscina cu ilustrații care completează procesul de asamblare. Elementele contractuale, cum ar fi ilustrațiile, pot varia, în ceea ce privește forma, culoarea și aspectul. Manufacturas Gre, în angajamentul său de îmbunătățire continuă a produselor lor, își rezervă dreptul de a modifica în orice moment și fără avertisment anterior caracteristicile, detaliile tehnice, echipamentele standardizate și diferitele opțiuni ale produselor sale.

SV OBS!

Läs denna information noggrant och förvara den för senare konsulteringar

Grattis för valet av din pool. Modellen du har valt är speciellt utformad för enkel och snabb installation, men vissa försiktighetsåtgärder för säker hantering och säker användning är nödvändiga. Innan du börjar med installationen och monteringen av din pool bör du överväga den nuvarande lokala förordningen om mark- och markpooler.

Användningen av poolkitten inkluderar att följa säkerhetsinstruktionerna som beskrivs i underhållet och bruksanvisningen. Om säkerhetsföreskrifterna inte följs kan allvarliga hälsoskador uppstå och speciellt för barn. Läs den här handboken noggrant och var uppmärksam på bilderna innan du börjar montera poolen. Om du inte följer denna bruksanvisning för montering av poolen, kan garantin avvisas vid misslyckande.

Informationen i denna handbok visar exakt hur poolen ska monteras med illustrationer som kompletterar monteringsprocessen. Avtalsenliga element som illustrationer kan variera beroende på form, färg och aspekt. Manufacturas Gre i sitt åtagande att ständigt förbättra sina produkter, förbehåller sig rätten att när som helst och utan föregående varning modifiera funktionerna, de tekniska detaljerna, den standardiserade utrustningen och de olika alternativen för sina produkter.

PICTOGRAMS - PIKTOGRAMY - PICTOGRAMS PICTOGRAMS - PICTOGRAMME - PICTOGRAM



Compulsory
Obowiązkowe

CS
SK

Obligatoriu
Obligatoriskt



Attention
Uwaga

CS
SK

Atenție
Observera



Comment
Komentarz

CS
SK

Comentariu
Kommentar



Suggestions
Sugestie

CS
SK

Sugestii
Förslag

GUARANTEE



Keep your manual with the serial number and the purchase justification (payment receipt) for any type of reclamation.



Any reclamation against guarantee should be made by an online declaration, via the www.grepool.com/en/after-sales website, together with receipt of purchase.

You may be asked for photographs to justify the claim. No returns of material will be accepted without previous agreement. The client will support all costs of all returns of goods, (packaging and transport).

AFTER VERIFICATION AND CONFIRMATION OF A MANUFACTURING DEFECT

- The products that effectively show defects will be repaired or will be replaced free of transport costs.
- An estimate will be provided for the products not included in the guarantee. After the client has accepted the estimate the parts will be delivered.

The guarantee is limited to the repair or replacement of the defective part. It does not include, under any circumstance, the payment of compensation for harm and damages.

THE GUARANTEE IS NOT APPLICABLE IN THE FOLLOWING SITUATIONS:

- Use of materials that do not comply to our instructions.
- Damages caused by mishandling or an installation not complying with the instructions.
- The maintenance instructions were not followed.
- Inappropriate or wrong use of the chemical product.

DURATION AND CONDITIONS OF THE WARRANTY:

The pool's warranty period against all the manufacturing defects it is 2 years. The requirement for this is that all the manual instructions in relation to the preparation, installation, use and security that come with the pool are followed at detail.

The pool's structure has a 5 year warranty since the date that the product has been purchased. This warranty covers insect attacks and rotting. The guarantee will not be valid for the following situations:

- Use of materials not in accord to our instructions.
- Incorrect use of chemical products for water maintenance
- Colour variations
- Provoked damage (breakages, scratches)
- Liner: 2 years for the seams and water tightness in normal conditions of use. The guarantee does not include: Ripping, tears, breakages, stains (caused by pouring treatment products directly into the water), stains linked to the growth of algae, stains related to the decomposition of foreign bodies in contact with the liner, stains and decolouring resulting from the action of oxidising products, colour maintenance and wear due to friction of the material over diverse surfaces. Deformation of the liner that has

been left without water for 24 hours (never completely empty the pool).

You should keep the label with the serial number of the liner that is on the product and on its packaging. This number and a sample of the liner will be required for any eventual reclamation against the guarantee.

- Stainless steel stepladder: 2 years. In the case of a filtration due to salt electrolysis, the guarantee will not cover the stepladder.
- Filter group: The pump has 2 years guarantee (electrical problem), in normal conditions of use. The guarantee does not cover breakage of parts (pump base/sand deposit, pre-filter cover, multi-directional trap...), wear due to a poor connection, use of the pump without water, wear due to abrasion or corrosion (the filter group should be located in a cool and dry position, kept protected from water splashing).
- Other components: 2 years.

THE FOLLOWING IS NOT INCLUDED IN THE GUARANTEE:

- Cuts in the liner
- The assembly and filter connection
- The assembly
- The filling with water
- Installation of the edges
- The wintering
- Maintenance

AFTER SALES SERVICE IN GUARANTEE:

(Change of piece after visual justification)

- Changing of COMPOSITE after visual verification.
- Period for change: 8 business days In the context of replacing a defective component, the disassembly and assembly is not the responsibility of Manufacturas Gre.

AFTER SALES SERVICE WITHOUT GUARANTEE:

The guarantee is valid in all the UE countries, UK and Switzerland. GRE offers the buyer -in addition to the rights of guarantee from the seller that correspond by law and without limiting them- an additional right according to the conditions of the following obligations guaranteed for new products.

MANUFACTURAS GRE S.A. | ARITZ BIDEA 57,
BELAKO INDUSTRIALDEA | 48100 Mungia (Vizcaya) España
| Nº REG. IND.: 48-06762

Made in Europe

e-mail: gre@gre.es

<http://www.grepool.com>

Spare parts available for 5 years counting from the product invoicing date.

PROLOGUE

SAFETY INSTRUCTIONS

The filter kit (filter + pump) should be installed at least 3.5 metres from the pool to avoid the risk of electrocution.

According to the regulation, there should be a special differential electricity protection device for pools with electric filter pumps.

Never leave children without surveillance near the pool.

After each bath, remove the external stepladder to avoid accidental falling into the pool of children or of pets (Regulation EN-P90-317).

This pool is exclusively designed for family use. Walking on the edges or diving or jumping from them is strictly forbidden.

DURATION OF THE INSTALLATION

The installation of this pool needs the intervention of at least two people and takes two days (besides the preparation of the land and the filling).

BEFORE BUILDING YOUR POOL MAKE SURE THAT

- You have the assistance of a qualified person for the electrical connections.
- There is sufficient water supply to fill the pool.
- That you have carefully read the manual, step by step, to fully understand the installation of your pool.

INSTALLATION SUGGESTION

The land should be prepared as indicated in the «installation» chapter of this manual.

DO NOT PLACE YOUR POOL

- Under overhead electricity cables
- Under branches of trees
- On non-stable land

A good location allows you to save time and avoid limitations. The pool should be in a sunny spot and easily reached.

The location of the pool should be free of tubes or electrical connections.

Take into account that the best is to assemble the pool on a sunny day and avoiding high winds.

PACKAGING, CLASSIFICATION AND RECYCLING

- Some pool components are packed in plastic bags. To avoid all risk of asphyxia, never allow babies or children to play with these.
- Thanks for respecting the European Union Laws and collaborating in protecting the environment.

Concrete slab

Dosing 350 kg/m³ (standardized type C125 430)

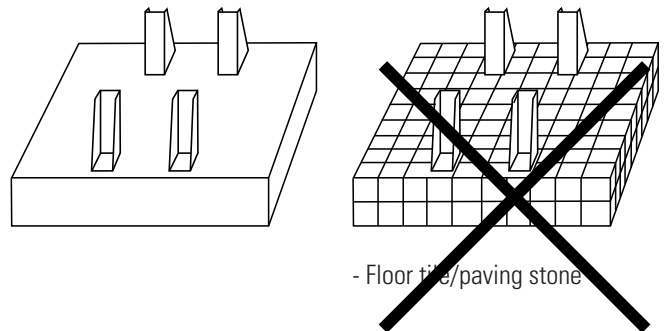

When you have installed your pool and all the components are assembled, we thank you for classifying and recycling all the packaging.

GWARANCJA



Zachowaj instrukcję obsługi z numerem seryjnym oraz potwierdzenie zakupu (potwierdzenie zapłaty) w celu dokonania ewentualnej reklamacji.



Wszelkie reklamacje z tytułu gwarancji powinny być zgłaszane przez internet, na stronie internetowej www.grepool.com/en/after-sales, załączając dowód zakupu.

W celu uzasadnienia reklamacji mogą zostać Państwo poproszeni o przesłanie zdjęć. Zwroty materiałów nie będą przyjmowane bez zawarcia wcześniejszego porozumienia w tej sprawie. Klient ponosi wszelkie koszty związane ze zwrotem towaru (za opakowanie i transport).

PO WERYFIKACJI I POTWIERDZENIU WADY PRODUKCYJNEJ

- Produkty, które faktycznie są wadliwe, zostaną naprawione lub wymienione bez kosztów transportu.
- Produkty nieobjęte gwarancją zostaną poddane wycenie. Części zostaną dostarczone po zaakceptowaniu kosztorysu przez klienta.

Gwarancja jest ograniczona do naprawy lub wymiany wadliwej części. W żadnym wypadku nie obejmuje ona wypłaty odszkodowania za szkody i straty.

GWARANCJA NIE MA ZASTOSOWANIA W NASTĘPUJĄCYCH SYTUACJACH:

- Użycie materiałów niezgodnych z naszymi instrukcjami.
- Uszkodzenia spowodowane niewłaściwą obsługą lub montażem niezgodnym z instrukcją.
- Nieprzestrzeganie instrukcji dotyczących konserwacji.
- Nieodpowiednie lub niewłaściwe użycie produktu chemicznego.

CZAS TRWANIA I WARUNKI GWARANCJI:

Okres gwarancji na wszystkie wady fabryczne basenu wynosi 2 lata. Warunkiem gwarancji jest szczegółowe przestrzeganie wszystkich załączonych do basenu instrukcji dotyczących przygotowania, montażu, użytkowania i bezpieczeństwa.

Struktura basenu jest objęta 5-letnią gwarancją od daty zakupu produktu. Gwarancja ta obejmuje ataki owadów i gnicie. Gwarancja nie będzie ważna w następujących sytuacjach:

- użycie materiałów niezgodnie z naszymi instrukcjami,
- nieprawidłowe stosowanie środków chemicznych do uzdatniania wody,
- zmiany koloru,
- uszkodzenia spowodowane przez użytkownika (pęknięcia i zadrapania).
- Liner: 2 lata w przypadku łączeń oraz szczelności w normalnych warunkach użytkowania. Gwarancja nie obejmuje: Sytuacji związanych z rozdarciem; porwaniem; pęknięciem; plamami związanymi z wlewaniem produktów uzdatniających bezpośrednio do wody, rozwojem glonów, rozkładem ciał obcych w kontakcie z linerem; plamami i odbarwieniami wynikającymi z działania produktów utleniających i utrzymywania się koloru; oraz zużyciem spowodowanym tarcieniem materiału o różne powierzchnie. Odształceń

linera pozostawionego przez 24 godziny bez wody (nigdy nie należy całkowicie opróżniać basenu).

Zachowaj etykietę z numerem seryjnym linera, która znajduje się na produkcie oraz na jego opakowaniu. Numer ten oraz próbka linera będą potrzebne do ewentualnej reklamacji w ramach gwarancji.

- Drabinka ze stali nierdzewnej: 2 lata. W przypadku filtracji spowodowanej elektrolizą soli, gwarancja nie obejmuje drabinki.
- Filtry: Pompa ma 2 lata gwarancji (w przypadku problemów elektrycznych) w normalnych warunkach użytkowania. Gwarancja nie obejmuje pęknięć części (podstawy pompy/zbiornika z piaskiem, pokrywy filtra wstępnego, zaworu wielokierunkowego itd.), zużycia wynikającego z nieodpowiedniego podłączenia, używania pompy bez wody, zużycia spowodowanego ścieraniem lub korozją (filtry powinny być umieszczone w chłodnym i suchym miejscu, chronione przed rozpryskami wody).
- Pozostałe elementy: 2 lata.

GWARANCJA NIE OBEJMUJE:

- nacięć na linerze,
- montażu i podłączenia filtra,
- montażu,
- napełniania wodą,
- montażu brzegów,
- przezimowania wody,
- konserwacji.

OBSŁUGA POSPRZEDAŻOWA W RAMACH GWARANCJI:

(Wymiana części po oględzinach)

- Wymiana KOMPOZYTU po oględzinach.
- Czas na wymianę: 8 dni roboczych. Jeśli chodzi o wymianę wadliwego elementu, jego demontaż i montaż nie są obowiązkiem Manufacturas Gre.

OBSŁUGA POSPRZEDAŻOWA BEZ GWARANCJI:

Gwarancja jest ważna we wszystkich krajach UE, w Wielkiej Brytanii i Szwajcarii.

GRE oferuje kupującemu – oprócz praw do gwarancji od sprzedawcy przysługujących zgodnie z prawem w sposób nieograniczony – dodatkowe prawo zgodnie z warunkami następujących zobowiązań gwarantowanych dla nowych produktów.

MANUFACTURAS GRE S.A. | ARITZ BIDEA 57,
BELAKO INDUSTRIALDEA | 48100 Mungia (Vizcaya) España
| N° REG. IND.: 48-06762
Made in Europe

e-mail: gre@gre.es <http://www.grepool.com>

Części zamienne dostępne przez 5 lat licząc od daty wystawienia faktury za zakup produktu.

WSTĘP

INSTRUKCJE BEZPIECZEŃSTWA

Zestaw filtracyjny (filtr + pompa) powinien zostać zainstalowany w odległości co najmniej 3,5 metra od basenu, aby zapobiec ryzyku porażenia prądem.

Zgodnie z obowiązującymi przepisami, baseny z elektrycznymi pompami filtrującymi muszą zostać wyposażone w specjalne urządzenie zabezpieczające przed prądem różnicowym.

Nigdy nie pozostawiaj dzieci bez nadzoru w pobliżu basenu.

Usuń zewnętrzną drabinkę po każdej kąpeli, aby zapobiec przypadkowemu wpadnięciu do basenu dzieci lub zwierząt domowych (rozporządzenie EN-P90-317).

Basen jest przeznaczony wyłącznie do użytku rodzinnego. Surowo zabrania się chodzenia po krawędziach basenu lub skakania z nich.

CZAS TRWANIA INSTALACJI

Do instalacji tego basenu potrzebne są co najmniej 2 osoby i trwa ona 2 dni (nie uwzględniając czasu potrzebnego na przygotowanie terenu i napełnienie basenu).

PRZED MONTAŻEM BASENU UPEWNIJ SIĘ, ŻE:

- Możesz liczyć na pomoc wykwalifikowanej osoby w celu wykonania połączeń elektrycznych.
- Masz wystarczający dopływ wody do napełnienia basenu.
- Zapoznałeś się dokładnie z instrukcją, aby w pełni zrozumieć proces montażu basenu.

SUGESTIE DOTYCZĄCE MONTAŻU:

Teren powinien zostać przygotowany zgodnie z zaleceniami zawartymi w rozdziale „Instalacja” niniejszej instrukcji.

NIE UMIESZCZAJ SWOJEGO BASENU:

- pod napowietrznymi przewodami elektrycznymi,
- pod gałęziami drzew,
- na niestabilnym podłożu.

Odpowiednio dobrane miejsce pozwala zaoszczędzić czas i uniknąć pewnych ograniczeń. Basen powinien zostać umieszczony w miejscu nasłonecznionym i łatwo dostępnym.

Powinien on również znajdować się z dala od rur i kabli elektrycznych. Instalacja basenu powinna zostać przeprowadzona w słoneczny dzień, unikając silnych wiatrów.

OPAKOWANIE, KLASYFIKACJA I RECYKLING

- Niektóre elementy basenu są pakowane w plastikowe torby. Aby zapobiec ryzyku uduszenia, nie pozwalaj niemowlętom i dzieciom bawić się nimi.
- Dziękujemy za przestrzeganie przepisów Unii Europejskiej i za współpracę w zakresie ochrony środowiska.

Dziękujemy za klasyfikację i recykling wszystkich opakowań po zainstalowaniu basenu i zmontowaniu wszelkich elementów.

GUARANTEE



Keep your manual with the serial number and the purchase justification (payment receipt) for any type of reclamation.



Any reclamation against guarantee should be made by an online declaration, via the www.grepool.com/en/after-sales website, together with receipt of purchase.

You may be asked for photographs to justify the claim. No returns of material will be accepted without previous agreement. The client will support all costs of all returns of goods, (packaging and transport).

AFTER VERIFICATION AND CONFIRMATION OF A MANUFACTURING DEFECT

- The products that effectively show defects will be repaired or will be replaced free of transport costs.
- An estimate will be provided for the products not included in the guarantee. After the client has accepted the estimate the parts will be delivered.

The guarantee is limited to the repair or replacement of the defective part. It does not include, under any circumstance, the payment of compensation for harm and damages.

THE GUARANTEE IS NOT APPLICABLE IN THE FOLLOWING SITUATIONS:

- Use of materials that do not comply to our instructions.
- Damages caused by mishandling or an installation not complying with the instructions.
- The maintenance instructions were not followed.
- Inappropriate or wrong use of the chemical product.

DURATION AND CONDITIONS OF THE WARRANTY:

The pool's warranty period against all the manufacturing defects it is 2 years. The requirement for this is that all the manual instructions in relation to the preparation, installation, use and security that come with the pool are followed at detail.

The pool's structure has a 5 year warranty since the date that the product has been purchased. This warranty covers insect attacks and rotting. The guarantee will not be valid for the following situations:

- Use of materials not in accord to our instructions.
- Incorrect use of chemical products for water maintenance
- Colour variations
- Provoked damage (breakages, scratches)
- Liner: 2 years for the seams and water tightness in normal conditions of use. The guarantee does not include: Ripping, tears, breakages, stains (caused by pouring treatment products directly into the water), stains linked to the growth of algae, stains related to the decomposition of foreign bodies in contact with the liner, stains and decolouring resulting from the action of oxidising products, colour maintenance and wear due to friction of the material over diverse surfaces. Deformation of the liner that has

been left without water for 24 hours (never completely empty the pool).

You should keep the label with the serial number of the liner that is on the product and on its packaging. This number and a sample of the liner will be required for any eventual reclamation against the guarantee.

- Stainless steel stepladder: 2 years. In the case of a filtration due to salt electrolysis, the guarantee will not cover the stepladder.
- Filter group: The pump has 2 years guarantee (electrical problem), in normal conditions of use. The guarantee does not cover breakage of parts (pump base/sand deposit, pre-filter cover, multi-directional trap...), wear due to a poor connection, use of the pump without water, wear due to abrasion or corrosion (the filter group should be located in a cool and dry position, kept protected from water splashing).
- Other components: 2 years.

THE FOLLOWING IS NOT INCLUDED IN THE GUARANTEE:

- Cuts in the liner
- The assembly and filter connection
- The assembly
- The filling with water
- Installation of the edges
- The wintering
- Maintenance

AFTER SALES SERVICE IN GUARANTEE:

(Change of piece after visual justification)

- Changing of COMPOSITE after visual verification.
- Period for change: 8 business days In the context of replacing a defective component, the disassembly and assembly is not the responsibility of Manufacturas Gre.

AFTER SALES SERVICE WITHOUT GUARANTEE:

The guarantee is valid in all the UE countries, UK and Switzerland. GRE offers the buyer -in addition to the rights of guarantee from the seller that correspond by law and without limiting them- an additional right according to the conditions of the following obligations guaranteed for new products.

MANUFACTURAS GRE S.A. | ARITZ BIDEA 57,
BELAKO INDUSTRIALDEA | 48100 Mungia (Vizcaya) España
| N° REG. IND.: 48-06762
Made in Europe

e-mail: gre@gre.es

<http://www.grepool.com>

Spare parts available for 5 years counting from the product invoicing date.

PROLOGUE

SAFETY INSTRUCTIONS

The filter kit (filter + pump) should be installed at least 3.5 metres from the pool to avoid the risk of electrocution.

According to the regulation, there should be a special differential electricity protection device for pools with electric filter pumps.

Never leave children without surveillance near the pool.

After each bath, remove the external stepladder to avoid accidental falling into the pool of children or of pets (Regulation EN-P90-317).

This pool is exclusively designed for family use. Walking on the edges or diving or jumping from them is strictly forbidden.

DURATION OF THE INSTALLATION

The installation of this pool needs the intervention of at least two people and takes two days (besides the preparation of the land and the filling).

BEFORE BUILDING YOUR POOL MAKE SURE THAT

- You have the assistance of a qualified person for the electrical connections.
- There is sufficient water supply to fill the pool.
- That you have carefully read the manual, step by step, to fully understand the installation of your pool.

INSTALLATION SUGGESTION

The land should be prepared as indicated in the «installation» chapter of this manual.

DO NOT PLACE YOUR POOL

- Under overhead electricity cables
- Under branches of trees
- On non-stable land

A good location allows you to save time and avoid limitations. The pool should be in a sunny spot and easily reached.

The location of the pool should be free of tubes or electrical connections.

Take into account that the best is to assemble the pool on a sunny day and avoiding high winds.

PACKAGING, CLASSIFICATION AND RECYCLING

- Some pool components are packed in plastic bags. To avoid all risk of asphyxia, never allow babies or children to play with these.
- Thanks for respecting the European Union Laws and collaborating in protecting the environment.

When you have installed your pool and all the components are assembled, we thank you for classifying and recycling all the packaging.

GUARANTEE



Keep your manual with the serial number and the purchase justification (payment receipt) for any type of reclamation.



Any reclamation against guarantee should be made by an online declaration, via the www.grepool.com/en/after-sales website, together with receipt of purchase.

You may be asked for photographs to justify the claim. No returns of material will be accepted without previous agreement. The client will support all costs of all returns of goods, (packaging and transport).

AFTER VERIFICATION AND CONFIRMATION OF A MANUFACTURING DEFECT

- The products that effectively show defects will be repaired or will be replaced free of transport costs.
- An estimate will be provided for the products not included in the guarantee. After the client has accepted the estimate the parts will be delivered.

The guarantee is limited to the repair or replacement of the defective part. It does not include, under any circumstance, the payment of compensation for harm and damages.

THE GUARANTEE IS NOT APPLICABLE IN THE FOLLOWING SITUATIONS:

- Use of materials that do not comply to our instructions.
- Damages caused by mishandling or an installation not complying with the instructions.
- The maintenance instructions were not followed.
- Inappropriate or wrong use of the chemical product.

DURATION AND CONDITIONS OF THE WARRANTY:

The pool's warranty period against all the manufacturing defects it is 2 years. The requirement for this is that all the manual instructions in relation to the preparation, installation, use and security that come with the pool are followed at detail.

The pool's structure has a 5 year warranty since the date that the product has been purchased. This warranty covers insect attacks and rotting. The guarantee will not be valid for the following situations:

- Use of materials not in accord to our instructions.
- Incorrect use of chemical products for water maintenance
- Colour variations
- Provoked damage (breakages, scratches)
- Liner: 2 years for the seams and water tightness in normal conditions of use. The guarantee does not include: Ripping, tears, breakages, stains (caused by pouring treatment products directly into the water), stains linked to the growth of algae, stains related to the decomposition of foreign bodies in contact with the liner, stains and decolouring resulting from the action of oxidising products, colour maintenance and wear due to friction of the material over diverse surfaces. Deformation of the liner that has

been left without water for 24 hours (never completely empty the pool).

You should keep the label with the serial number of the liner that is on the product and on its packaging. This number and a sample of the liner will be required for any eventual reclamation against the guarantee.

- Stainless steel stepladder: 2 years. In the case of a filtration due to salt electrolysis, the guarantee will not cover the stepladder.
- Filter group: The pump has 2 years guarantee (electrical problem), in normal conditions of use. The guarantee does not cover breakage of parts (pump base/sand deposit, pre-filter cover, multi-directional trap...), wear due to a poor connection, use of the pump without water, wear due to abrasion or corrosion (the filter group should be located in a cool and dry position, kept protected from water splashing).
- Other components: 2 years.

THE FOLLOWING IS NOT INCLUDED IN THE GUARANTEE:

- Cuts in the liner
- The assembly and filter connection
- The assembly
- The filling with water
- Installation of the edges
- The wintering
- Maintenance

AFTER SALES SERVICE IN GUARANTEE:

(Change of piece after visual justification)

- Changing of COMPOSITE after visual verification.
- Period for change: 8 business days In the context of replacing a defective component, the disassembly and assembly is not the responsibility of Manufacturas Gre.

AFTER SALES SERVICE WITHOUT GUARANTEE:

The guarantee is valid in all the UE countries, UK and Switzerland. GRE offers the buyer -in addition to the rights of guarantee from the seller that correspond by law and without limiting them- an additional right according to the conditions of the following obligations guaranteed for new products.

MANUFACTURAS GRE S.A. | ARITZ BIDEA 57,
BELAKO INDUSTRIALDEA | 48100 Mungia (Vizcaya) España
| N° REG. IND.: 48-06762
Made in Europe

e-mail: gre@gre.es

<http://www.grepool.com>

Spare parts available for 5 years counting from the product invoicing date.

PROLOGUE

SAFETY INSTRUCTIONS

The filter kit (filter + pump) should be installed at least 3.5 metres from the pool to avoid the risk of electrocution.

According to the regulation, there should be a special differential electricity protection device for pools with electric filter pumps.

Never leave children without surveillance near the pool.

After each bath, remove the external stepladder to avoid accidental falling into the pool of children or of pets (Regulation EN-P90-317).

This pool is exclusively designed for family use. Walking on the edges or diving or jumping from them is strictly forbidden.

DURATION OF THE INSTALLATION

The installation of this pool needs the intervention of at least two people and takes two days (besides the preparation of the land and the filling).

BEFORE BUILDING YOUR POOL MAKE SURE THAT

- You have the assistance of a qualified person for the electrical connections.
- There is sufficient water supply to fill the pool.
- That you have carefully read the manual, step by step, to fully understand the installation of your pool.

INSTALLATION SUGGESTION

The land should be prepared as indicated in the «installation» chapter of this manual.

DO NOT PLACE YOUR POOL

- Under overhead electricity cables
- Under branches of trees
- On non-stable land

A good location allows you to save time and avoid limitations. The pool should be in a sunny spot and easily reached.

The location of the pool should be free of tubes or electrical connections.

Take into account that the best is to assemble the pool on a sunny day and avoiding high winds.

PACKAGING, CLASSIFICATION AND RECYCLING

- Some pool components are packed in plastic bags. To avoid all risk of asphyxia, never allow babies or children to play with these.
- Thanks for respecting the European Union Laws and collaborating in protecting the environment.

When you have installed your pool and all the components are assembled, we thank you for classifying and recycling all the packaging.

GARANȚIE



Păstrați manualul cu numărul de serie și justificarea de achiziție (chitanță de plată) pentru orice tip de reclamație.



Orice reclamație împotriva garanției trebuie făcută printr-o declarație online, prin intermediul site-ului www.grepool.com/en/aftersales, împreună cu primirea achiziției.

Orice reclamație împotriva garanției trebuie făcută printr-o declarație online, prin intermediul site-ului www.grepool.com/en/aftersales, împreună cu primirea achiziției.

Este posibil să vi se ceară fotografii pentru a justifica revendicarea. Nu se vor accepta returnări de materiale fără acordul prealabil. Clientul va suporta toate costurile tuturor returnărilor de mărfuri (ambalare și transport).

DUPĂ VERIFICARE ȘI CONFIRMAREA UNUI DEFECT DE FABRICAȚIE

• Produsele care prezintă efectiv defecte vor fi reparate sau vor fi înlocuite fără costuri de transport.

• Se va furniza o estimare pentru produsele care nu sunt incluse în garanție.

După ce clientul a acceptat devizul, piesele vor fi livrate.

Garanția se limitează la repararea sau înlocuirea piesei defecte. Nu include, în niciun caz, plata despăgubirilor pentru daune.

GARANȚIA NU SE APLICĂ ÎN URMĂTOARELE SITUAȚII:

- Utilizarea materialelor care nu respectă instrucțiunile noastre.
- Daune cauzate de o manipulare greșită sau de o instalare care nu respectă instrucțiunile.
- Instrucțiunile de întreținere nu au fost respectate.
- Utilizarea necorespunzătoare sau greșită a produsului chimic.

DURATA ȘI CONDIȚIILE GARANȚIEI:

Perioada de garanție a piscinei împotriva tuturor defectelor de fabricație este de 2 ani. Cerința pentru aceasta este ca toate instrucțiunile manuale referitoare la pregătirea, instalarea, utilizarea și securitatea care vin împreună cu piscina să fie respectate în detaliu.

Structura piscinei are o garanție de 5 ani de la data achiziționării produsului. Această garanție acoperă atacurile de insecte și putrezirea. Garanția nu va fi valabilă pentru următoarele situații:

- Utilizarea materialelor care nu sunt în conformitate cu instrucțiunile noastre.
- Utilizarea incorectă a produselor chimice pentru întreținerea apei
- Variații de culoare
- Daune provocate (rupturi, zgârieturi)
- Căptușeală: 2 ani pentru cusături și etanșeitatea la apă în condiții normale de utilizare. Garanția nu include: rupere, rupere, rupturi, pete (cauzate de turnarea produselor de tratament direct în apă), pete legate de creșterea algelor, pete legate de descompunerea corpurilor străine în contact cu căptușeala, pete și decolorare rezultat din acțiunea produselor oxidante, menținerea culorii și uzura datorită frecării materialului pe diverse suprafețe.

Deformarea căptușelii care a rămas fără apă timp de 24 de ore (nu goliți niciodată complet piscina).

Ar trebui să păstrați eticheta cu numărul de serie al căptușelii care se află pe produs și pe ambalajul acestuia. Acest număr și un eșantion de căptușeală vor fi necesare pentru orice eventuală recuperare a garanției.

• Scară din oțel inoxidabil: 2 ani. În cazul unei filtrări cauzate de electroliza sării, garanția nu va acoperi scara.

• Grup de filtrare: Pompa are 2 ani garanție (problemă electrică), în condiții normale de utilizare. Garanția nu acoperă ruperea pieselor (baza pompei / depunerea nisipului, capacul prefiltrului, capcană multidirecțională ...), uzura datorată unei conexiuni slabe, utilizarea pompei fără apă, uzura datorită abraziunii sau coroziunii (grupul de filtrare trebuie amplasat într-o poziție rece și uscată, protejat de stropirea apei).

• Alte componente: 2 ani.

URMĂTOARELE NU SUNT INCLUSE ÎN GARANȚIE:

- Tăieturi în căptușeală
- Asamblarea și conexiunea filtrului
- Adunarea
- Umplutura cu apa
- Instalarea marginilor
- Iernarea
- Întreținere

SERVICIU DUPĂ VÂNZARE ÎN GARANȚIE:

(Schimbarea piesei după justificarea vizuală)

- Schimbarea COMPOZITULUI după verificarea vizuală.
- Perioada de schimbare: 8 zile lucrătoare în contextul înlocuirii unei componente defecte, demontarea și asamblarea nu sunt responsabilitatea Manufacturas Gre.

SERVICIU POST VÂNZĂRI FĂRĂ GARANȚIE:

Garanția este valabilă în toate țările UE, Marea Britanie și Elveția. GRE oferă cumpărătorului - în plus față de drepturile de garanție de la vânzător care corespund prin lege și fără a limita dreptul suplimentar al omului în conformitate cu condițiile următoarelor obligații garantate pentru produsele noi.

MANUFACTURAS GRE S.A. | ARITZ BIDEA 57,
BELAKO INDUSTRIALDEA | 48100 Mungia (Vizcaya) España
| N° REG. IND.: 48-06762
Made in Europe

e-mail: gre@gre.es

<http://www.grepool.com>

Piese de schimb disponibile timp de 5 ani de la data facturării produsului.

PROLOG

INSTRUCIUNI DE SIGURANTA

Setul de filtrare (filtru + pompă) trebuie instalat la cel puțin 3,5 metri de piscină pentru a evita riscul de electrocutare. Conform regulamentului, ar trebui să existe un dispozitiv diferențial special de protecție a energiei electrice pentru bazinele cu pompe cu filtru electric. Nu lăsați niciodată copiii fără supraveghere lângă piscină. După fiecare baie, îndepărtați scara externă pentru a evita căderea accidentală în piscina copiilor sau a animalelor de companie (Regulamentul EN-P90-317). Această piscină este concepută exclusiv pentru uz familial. Mersul pe margini sau scufundările sau săriturile de pe ele sunt strict interzise.

DURATA INSTALAȚIEI

Instalarea acestei bazine necesită intervenția a cel puțin două persoane și durează două zile (în afară de pregătirea terenului și de umplere).

ÎNAINTE DE A CONSTRUI PISCINA ASIGURAȚI-VĂ CĂ

- Aveți asistența unei persoane calificate pentru conexiunile electrice.
- Există suficientă apă pentru a umple piscina.
- Că ați citit cu atenție manualul, pas cu pas, pentru a înțelege pe deplin instalarea piscinei dvs.

SUGESTIE DE INSTALARE

Terenul trebuie pregătit conform indicațiilor din capitolul „instalare” din acest manual.

NU PLASAȚI PISCINA

- Sub cabluri aeriene de electricitate
- Sub ramuri de copaci
- Pe terenuri nestabile

O locație bună vă permite să economisiți timp și să evitați limitările. Piscina ar trebui să fie într-un loc însorit și ușor accesibilă. Amplasarea piscinei nu trebuie să conțină tuburi sau conexiuni electrice.

Luați în considerare faptul că cel mai bun este să asamblați piscina într-o zi însorită și să evitați vânturile puternice.

AMBALARE, CLASIFICARE ȘI REICLARE

- Unele componente ale piscinei sunt ambalate în pungi de plastic. Pentru a evita orice risc de asfixie, nu permiteți niciodată copiilor sau copiilor să se joace cu acestea.
- Vă mulțumim că ați respectat legile Uniunii Europene și că ați colaborat la protejarea mediului.

După ce ați instalat piscina și toate componentele sunt asamblate, vă mulțumim că ați clasificat și reciclat toate ambalajele.

GARANTI



Förvara din handbok med serienummer och inköpsfakta (betalningskvitto) för alla typer av krav.



Varje klagomål mot garantin bör göras genom en onlinedeklaration via www.grepool.com/en/afterforsaljningswebbplats, tillsammans med mottagande av köp.

Du kan bli ombedd att ta bilder för att motivera klagomålet. Ingen retur av material accepteras utan föregående avtal. Kunden stöder alla kostnader för all retur av varor, (förpackning och transport).

EFTER VERIFIERING OCH BEKRÄFTNING AV ETT TILLVERKNINGSFEL

- Produkter som effektivt visar defekter kommer att repareras eller ersättas utan transportkostnader.
- En uppskattning kommer att tillhandahållas för de produkter som inte ingår i garantin. Efter att kunden har accepterat uppskattningen kommer delarna att levereras.

Garantin är begränsad till reparation eller utbyte av den defekta delen. Det inkluderar inte, under några omständigheter, betalning av ersättning för skador och skador.

GARANTIN GÄLLER INTE I FÖLJANDE SITUATIONER::

- Användning av material som inte följer våra instruktioner.
- Skador orsakade av felaktig hantering eller en installation som inte följer instruktionerna.
- Underhållsinstruktionerna följdes inte.
- Olämplig eller felaktig användning av den kemiska produkten.

GARANTINS VARIGHET OCH VILLKOR:

Poolens garantiperiod mot alla tillverkningsfel är 2 år. Kravet på detta är att alla manuella instruktioner i samband med förberedelse, installation, användning och säkerhet som följer med poolen följs i detalj.

Poolens struktur har 5 års garanti sedan det datum då produkten köptes. Denna garanti täcker insektsattacker och ruttande.

Garantin gäller inte i följande situationer:

- Användning av material som inte följer våra instruktioner.
- Felaktig användning av kemiska produkter för vattenunderhåll
- Färgvariationer
- Framkallad skada (brott, repor)
- Foder: 2 år för sömmarna och vattentätheten under normala användningsförhållanden. Garantin inkluderar inte: Rippning, tårar, brott, fläckar (orsakade av att hälla behandlingsprodukter direkt i vattnet), fläckar kopplade till algutväxt, fläckar relaterade till nedbrytning av främmande kroppar i kontakt med linern, fläckar och avfärgning till följd av oxidationsverkan produkter, färgunderhåll och slitage på grund av friktion av materialet på olika ytor. Deformation av linern som har stått utan vatten i 24 timmar (töm aldrig poolen helt).

Du bör förvara etiketten med serienumret på linern som finns på produkten och på dess förpackning. Detta nummer och ett prov på

linern krävs för eventuell återvinning av garantin.

- *Stege i rostfritt stål: 2 år. I händelse av en filtrering på grund av saltelektrolys täcker inte garantin trappstegen.*
- *Filtrera grupp: Pumpen har två års garanti (elproblem) under normala användningsförhållanden. Garantin täcker inte brott på delar (pumpbas / sandavlagring, förfilterlock, flerriktad fälla ...), slitage på grund av dålig anslutning, användning av pumpen utan vatten, slitage på grund av nötning eller korrosion (filtergruppen ska placeras svalt och torrt, skyddas från vattenstänk).*
- *Andra komponenter: 2 år.*

FÖLJANDE INGÅR INTE I GARANTIN:

- Skär i linern
- Montering och filteranslutning
- Församlingen
- Fyllningen med vatten
- Montering av kanterna
- Vintern
- Underhåll

EFTER FÖRSÄLJNINGSTJÄNSTER I GARANTI:

(Byte av del efter visuell motivering)

- Ändring av COMPOSITE efter visuell verifiering.
- Period för förändring: 8 arbetsdagar i samband med byte av en defekt komponent är det inte tillverkningens ansvar att ta isär och montera.

EFTER FÖRSÄLJNINGSTJÄNST UTAN GARANTI:

Garantin gäller i alla UE-länder, Storbritannien och Schweiz. GRE erbjuder köparen -utöver de garantirättigheter från säljaren som motsvarar enligt lag och utan att begränsa dem- en ytterligare rättighet enligt villkoren i följande skyldigheter garanterade för nya produkter.

**MANUFACTURAS GRE S.A. | ARITZ BIDEA 57,
BELAKO INDUSTRIALDEA | 48100 Mungia (Vizcaya) España
| N° REG. IND.: 48-06762
Made in Europe**

e-mail: gre@gre.es

<http://www.grepool.com>

Reservdelar tillgängliga i 5 år räknat från produktens faktureringsdatum.

PROLOG

SÄKERHETSINSTRUKTIONER

Filterkitten (filterpumpen) bör installeras minst 3,5 meter från poolen för att undvika risk för elektrostöt.

Enligt förordningen bör det finnas en särskild differentiell elskyddsanordning för pooler med elektriska filterpumpar. Lämna aldrig barn utan övervakning nära poolen.

Ta bort den yttre trappstegen efter varje bad för att undvika att oavsiktligt falla i poolen för barn eller husdjur (föreskrift EN-P90-317). Denna pool är uteslutande utformad för familjeanvändning. Att gå på kanterna eller dyka eller hoppa från dem är strängt förbjudet.

INSTALLATIONENS VARAKTIGHET

Installationen av denna pool behöver ingripa av minst två personer och tar två dagar (förutom förberedelse av marken och fyllningen).

INNAN DU BYGGER DIN POOL, SE TILL ATT DET ÄR

- Du får hjälp av en kvalificerad person för de elektriska anslutningarna.
- Det finns tillräcklig vattenförsörjning för att fylla poolen.
- Att du noggrant har läst handboken steg för steg för att förstå installationen av din pool.

INSTALLATIONSFÖRSLAG

Marken bör beredas enligt kapitlet «installation» i denna handbok.

PLACERA INTE DIN POOL

- Under elektriska kablar
- Under trädgrenar
- På icke-stabil mark

En bra plats gör att du kan spara tid och undvika begränsningar.

Poolen ska vara på en solig plats och lätt nås.

Poolens placering bör vara fri från rör eller elektriska anslutningar.

Tänk på att det bästa är att montera poolen på en solig dag och undvika starka vindar.

FÖRPACKNING, KLASSIFICERING OCH ÅTERVINNING

- Vissa poolkomponenter är förpackade i plastpåsar. För att undvika all risk för kvävning, låt aldrig spädbarn eller barn leka med dessa.
- Tack för att du respekterar Europeiska unionens lagar och samarbetar för att skydda miljön.

När du har installerat din pool och alla komponenter är monterade tackar vi dig för att klassificera och återvinna all förpackning.

Carefully read, understand, and follow all information in this user manual before installing and using the swimming pool.

These warnings, instructions, and safety guidelines address some common risks of water recreation, but they cannot cover all risks and dangers in all cases. Always be cautious, common sense, and good judgment when enjoying any water activity. Retain this information for future use.

Non Swimmers safety

Continuous, active, and vigilant supervision of weak swimmers and non-swimmers by a competent adult is required at all times (remembering that children under five are at the highest risk of drowning).

- Designate a competent adult to supervise the pool each time it is being used.
- Weak swimmers or non-swimmers should wear personal protection equipment when using the pool.
- When the pool is not in use, or unsupervised, remove all toys from the swimming pool and its surrounding to avoid attracting children to the pool.

Safety devices

- It is recommended to install a barrier (and secure all doors and windows, where applicable) to prevent unauthorized access to the swimming pool.
- Barriers, pool covers, pool alarms, or similar safety devices are helpful aids, but they are not substitutes for continuous and competent adult supervision.

Safety equipment

- It is recommended to keep rescue equipment (e.g. a ring buoy) by the pool.
- Keep a working phone and a list of emergency phone numbers near the pool.

Safe use of the pool

- Encourage all users especially children to learn how to swim
 - Learn Basic Life Support (Cardiopulmonary Resuscitation - CPR) and refresh this knowledge regularly.
- This can make a life-saving difference in the event of an emergency.

This can make a life-saving difference in the event of an emergency.

- Instruct all pool users, including children, what to do in case of an emergency
- Never dive into any shallow body of water. This can lead to serious injury or death.
- Do not use the swimming pool when using alcohol or medication that may impair your ability to safely use the pool.
- When pool covers are used, remove them completely from the water surface before entering the pool.
- Protect pool occupants from water related illnesses by keeping the pool water treated and practicing good hygiene. Consult the water treatment guidelines in the user's manual.
- Store chemicals (e.g. water treatment, cleaning or disinfection products) out of the reach of children.
- Signage is to be displayed in a prominent position within 2 m of the pool.
- Removable ladders shall be placed on a horizontal surface.

WARNING:

Every electrical appliance fed in 220 V, has to be located at least at 3,50 m from the edge of the pool. The equipment should be connected to a voltage, with earth connection, protected by a residual current device (RCD) having a rated residual operating current not exceeding 30 mA.

Read the instructions carefully and keep for future reference.

IF YOU HAVE ANY PROBLEM CONTACT US!

web: www.greepool.com/en/aftersales

Przed instalacją oraz użytkowaniem basenu należy dokładnie przeczytać, zrozumieć i przestrzegać wszelkie zalecenia zawarte w niniejszej instrukcji obsługi. Niniejsze ostrzeżenia, instrukcje i wytyczne dotyczące bezpieczeństwa odnoszą się do niektórych typowych zagrożeń związanych z rekreacją w wodzie, natomiast nie obejmują wszystkich zagrożeń i niebezpieczeństw we wszystkich przypadkach.

Zawsze zachowuj ostrożność, kieruj się zdrowym rozsądkiem i rozsądnie oceniaj sytuację podczas wszelkich zabaw w wodzie. Zachowaj niniejszą instrukcję do wglądu w przyszłości.

Bezpieczeństwo osób nieumiejących pływać.

Podczas kąpieli należy zachować ciągły, aktywny i czujny nadzór nad osobami nieumiejącymi pływać. Obecność kompetentnej osoby dorosłej jest wymagana przez cały czas (biorąc pod uwagę fakt, że dzieci poniżej piątego roku życia są najbardziej narażone na utonięcie).

- Należy wyznaczyć kompetentną osobę dorosłą, która będzie nadzorować basen za każdym razem, gdy będzie on używany.
- Osoby słabo pływające lub nieumiejące pływać powinny nosić środki ochrony osobistej podczas korzystania z basenu.
- Gdy basen nie jest używany lub nie jest nadzorowany, należy usunąć z niego i z jego otoczenia wszelkie zabawki, aby nie przyciągać dzieci.

Urządzenia zabezpieczające

- Zaleca się zainstalowanie barierki (oraz zabezpieczenie wszystkich drzwi i okien, jeżeli znajdują się w pobliżu basenu), aby uniemożliwić dostęp do niego osobom nieupoważnionym.
- Barierki, osłony i alarmy basenowe lub podobne urządzenia zabezpieczające są pomocne, ale nie zastępują stałego i kompetentnego nadzoru dorosłych.

Sprzęt ratowniczy

- Zaleca się przechowywanie sprzętu ratowniczego (np. koła ratunkowego) przy basenie.
- W pobliżu basenu musi znajdować się sprawny telefon i lista numerów alarmowych.

Bezpieczne korzystanie z basenu

- Zachęcaj wszystkich użytkowników, zwłaszcza dzieci, do nauki pływania.
- Weź udział w kursie pierwszej pomocy i regularnie odświeżaj swoją wiedzę w tym zakresie.

W ten sposób możesz przyczynić się do uratowania komuś życia w razie nagłego wypadku.

- Wyjaśnij wszystkim użytkownikom basenu, w tym dzieciom, co należy zrobić w razie nagłego wypadku.
- Pod nadzorem instruktora nauki pływania, przed przystąpieniem do płytkiego zbiornika wodnego. Może to doprowadzić do poważnych obrażeń lub śmierci.
- Nie wolno korzystać z basenu pod wpływem alkoholu lub leków, które mogą negatywnie wpłynąć na zdolność bezpiecznego korzystania z niego.
- W przypadku używania osłon basenowych, należy całkowicie usunąć je z powierzchni wody, przed wejściem do basenu.
- Należy zadbać o ochronę użytkowników basenu przed chorobami związanymi z nieodpowiednio uzdatnioną wodą, poprzez stosowanie odpowiednich środków czyszczących i utrzymanie prawidłowej higieny. Należy zapoznać się z wytycznymi dotyczącymi uzdatniania wody zawartymi w instrukcji obsługi.
- Przechowuj środki chemiczne (np. środki do uzdatniania wody, czyszczenia lub dezynfekcji) w miejscu niedostępnym dla dzieci.
- Należy zadbać o odpowiednie oznakowanie w widocznym miejscu, w odległości 2 m od basenu.
- Zdejmowane drabinki basenowe powinny zostać umieszczone na poziomej powierzchni.

UWAGA:

Każde urządzenie elektryczne zasilane napięciem 220 V musi zostać umieszczone w odległości co najmniej 3,50 m od krawędzi basenu. Urządzenie należy podłączyć do gniazdka z uziemieniem, chronionego za pomocą urządzenia różnicowoprądowego (RCD) o znamionowym szczytkowym prądzie roboczym nieprzekraczającym 30 mA.

Zapoznaj się uważnie z niniejszą instrukcją i zachowaj ją do wglądu w przyszłości.

JEŚLI MASZ JAKIKOLWIEK PROBLEM, SKONTAKTUJ SIĘ Z NAM!

web: www.greepool.com/en/aftersales

Před instalací a použitím plaveckého bazénu si důkladně prostudujte tento návod, musíte mu rozumět a přísně jej dodržovat. Tyto výstrahy, pokyny a bezpečnostní informace pokrývají některá běžná rizika vodní rekreace, ale nemohou být vyčerpávající. Při vodních hrátkách buďte vždy opatrní, používejte zdravý rozum a logický úsudek. Tyto informace si uschovejte pro budoucí použití.

Bezpečnost neplavců

Neplavci a špatní plavci potřebují trvalý aktivní a pozorný dohled kompetentní dospělé osobou (pamatujte, že děti do pěti let jsou vystaveny nejvyššímu riziku utonutí).

- Určete kompetentní dospělé osobu pro dohled nad bazénem vždy, když je používán.
- Neplavci a špatní plavci by při používání bazénu měli vždy používat ochranné plavecké vesty nebo jiné ochranné pomůcky.
- Pokud se bazén nepoužívá nebo je ponechán bez dozoru, odstraňte z něj a z jeho okolí všechny hračky, aby nelákal děti.

Bezpečnostní prostředky

Pro prevenci neoprávněného vstupu do bazénu doporučujeme instalovat oplocení nebo ohrazení (se zajištěnými dveřmi a okny, pokud se bude jednat o zeď).

- Plot, kryt bazénu, alarm a podobné bezpečnostní prostředky jsou užitečné pomůcky, ale nenahrazují trvalý kompetentní dohled dospělou osobou.

Bezpečnostní vybava bazénu

- Doporučujeme vybavit bazén záchrannými prostředky (jako je kruhová bóje).
- U bazénu mějte funkční telefon a seznam důležitých telefonních čísel včetně záchranné služby.

Bezpečné používání bazénu

- Vyzvěte všechny uživatele, zejména děti, aby se nejrpe naučili plavat.
- Naučte se základy první pomoci (včetně umělého dýchání a nepřímé masáže srdce) a pravidelně si tyto znalosti osvěžujte.

To může v případě nouze pomoci zachránit lidský život.

- Poučte všechny uživatele bazénu, včetně dětí, co dělat v případě nouze.
- Do mělké vody nikdy neskákejte střemhlav. Může to vést k závažnému úrazu nebo smrti.
- Bazén nepoužívejte pod vlivem alkoholu nebo léků, které by mohly snížit vaši schopnost bezpečného používání bazénu.
- Pokud používáte krytí bazénu, před vstupem do vody je zcela odstraňte.
- Chraňte uživatele bazénu před chorobami souvisejícími se špinavou vodou pravidelným ošetřováním vody v bazénu a dodržováním potřebné hygieny. Prostudujte si pokyny k ošetřování vody uvedené v uživatelské příručce.
- Chemikálie (pro ošetření, čištění a desinfekci vody) uchovávejte mimo dosah dětí.
- Na viditelná místa ve vzdálenosti 2 metry od bazénu rozmístíte výstražné tabule.
- Odnímatelné žebříky pokládejte na vodorovnou plochu.

VÝSTRAHA:

Každý elektrický spotřebič napájený 220 V musí být umístěn ve vzdálenosti nejméně 3,5 m od okraje bazénu.

Zařízení musí být připojeno ke zdroji napájení s uzemněním chráněnému ochranou před zbytkovým proudem (RCD) se jmenovitým provozním proudem maximálně 30 mA.

Návod si důkladně prostudujte a uschovejte pro budoucí použití.

V PŘÍPADĚ JAKÉHOKOLIV PROBLÉMU NÁS KONTAKTUJTE!

web: www.greepool.com/en/aftersales





BEZPEČNOSTNÉ OPATRENIA

Pred inštaláciou a používaním bazénu si starostlivo prečítajte, porozumejte a dodržiavajte všetky informácie v tomto návode na použitie. Tieto varovania, inštrukcie a bezpečnostné pokyny sa zaoberajú niektorými bežnými rizikami vodnej rekreácie, ale nemôžu pokryť všetky riziká a nebezpečenstvá vo všetkých prípadoch. Pri akejkoľvek vodnej aktivite buďte vždy opatrní, používajte zdravý rozum a dobrý úsudok. Tieto informácie pre budúce použitie.

Bezpečnosť neplavcov

Neustály, aktívny a ostržitý dohľad nad slabšími plavcami a neplavcami kompetentným dospelým je vždy potrebný (pamätajte na to, že deti do päť majú najvyššie riziko utopenia).
- Pri každom použití určite kompetentnú dospelú osobu, ktorá bude dohliadať na bazén.
- Slabí plavci alebo neplavci by pri používaní bazéna mali používať osobné ochranné prostriedky.
- Pokiaľ sa bazén nepoužíva alebo je bez dozoru, odstráňte z neho a jeho okolia všetky hračky, aby ste doň nelákali deti.

Bezpečnostné zariadenia

- Odporúčajú sa nainštalovať zábranu (a podľa potreby zabezpečiť všetky dvere a okná), aby sa zabránilo neoprávnenému vstupu do bazéna.
- Zábrany, kryty bazénov, alarmy bazénov alebo podobné bezpečnostné zariadenia sú užitočnými pomocníkmi, ale nie sú náhradou za nepretržitý a kompetentný dohľad dospelého osoby.

Bezpečnostné vybavenie

- Záchrané vybavenie (napr. kruhovú bóju) sa odporúča mať pri bazéne.
- V blízkosti bazéna majte funkčný telefón a zoznam núdzových telefónnych čísel.

Bezpečné používanie bazéna

- Povzbudzujte všetkých používateľov, najmä deti, aby sa naučili plávať
- Naučte sa základnú podporu života (kardiopulmonárna resuscitácia - KPR) a pravidelne si tieto znalosti obnovujte.

V prípade núdze to môže znamenať záchranu života.

- Poučte všetkých používateľov bazéna, vrátane detí, čo majú robiť v prípade núdze
- Nikdy sa neponárajte do žiadnej plytkej vody. Môže to viesť k vážnemu zraneniu alebo smrti.
- Nepoužívajte bazén, ak používate alkohol alebo lieky, ktoré môžu narušiť vašu schopnosť bezpečne používať bazén.
- Keď sa používajú kryty bazéna, pred vstupom do bazéna ich úplne odstráňte z vodnej hladiny.
- Chráňte používateľov bazéna pred chorobami súvisiacimi s vodou tým, že budete vodu v bazéne upravovať a budete dodržiavať správnu hygienu. Prečítajte si pokyny pre úpravu vody v užívateľskej príručke.
- Chemikálie (napr. prostriedky na úpravu vody, čistiace alebo dezinfekčné prostriedky) skladujte mimo dosahu detí.
- Značenie musí byť zobrazené na viditeľnom mieste do 2 m od bazéna.
- Odnímateľné rebriky sa umiestnia na vodorovný povrch.

UPOZORNENIE:

Každý elektrický spotrebič napájaný 220 V musí byť tlmieňnený najmenej 3,50 m od okraja bazénu. Zariadenie by malo byť pripojené k n a p a t i u s u zmenením chráneným zariadením na zvyškový prúd (RCD) s menovitým zvyškovým prevádzkovým prúdom nepresahujúcim 30 mA.

Pozorne si prečítajte pokyny a uschovajte ich na použitie v budúcnosti.

AK MÁTE AKÝKOLVEK
PROBLÉM, KONTAKTUJTE NÁS!

web: www.grepool.com/en/aftersales



PRECAUȚII DE SIGURANȚĂ

Citiți cu atenție, înțelegeți și urmați toate informațiile din acest manual de utilizare înainte de a instala și utiliza piscina.
Aceste avertismente, instrucțiuni și instrucțiuni de siguranță abordează unele riscuri comune ale recreerii pe apă, dar nu pot acoperi toate riscurile și pericolele în toate cazurile. Folosiți întotdeauna prudență, bun simț și bună judecată atunci când vă bucurați de orice activitate de apă. Păstrați aceste informații pentru a utiliza re viitoare.

Siguranța non-înotătorilor

slabi și a celor care nu înnoată de către un adult competent este necesară în orice moment (amintindu-vă că copiii cu vârsta sub cinci ani prezintă cel mai mare risc de înecare).
- Desemnați un adult competent care să supravegheze piscina de fiecare dată când este utilizată.
- Înotători slabi, non-înotătorii trebuie să poarte echipament de protecție personală atunci când folosesc piscina.
- Când piscina nu este utilizată sau nesupravegheată, scoateți toate jucăriile din piscină și din împrejurimi pentru a evita atragerea copiilor la piscină.

Dispozitivele de siguranță

- Se recomandă instalarea unei bariere (și securizarea tuturor ușilor și ferestrelor, dacă este cazul) pentru a preveni accesul neautorizat la piscină.
- Barierele, capacele pentru piscină, alarmele pentru piscină sau dispozitive de siguranță similare sunt ajutoare utile, dar nu sunt înlocuitori pentru supravegherea continuă și competentă a adulților.

Echipament de siguranță

- Se recomandă păstrarea echipamentului de salvare (de exemplu, o geamandură inelară) lângă piscină.
- Păstrați un telefon funcțional și o listă cu numerele de telefon de urgență lângă piscină.

Utilizarea în siguranță a piscinei

- Încurajați toți utilizatorii, în special copiii, să învețe cum să înoate.
- Învățați măsurile de prim ajutor (Resuscitarea cardiopulmonară - RCP) și reîmprospătați aceste cunoștințe în mod regulat.

Acest lucru poate face o diferență în salvarea vieții în caz de urgență.

- Instruiți toți utilizatorii piscinei, inclusiv copiii, ce să facă în caz de urgență
- Nu vă scufundați niciodată în niciun fel de corp de apă. Acest lucru poate duce la vătămări grave sau la moarte.
- Nu utilizați piscină când utilizați alcool sau medicamente care vă pot afecta capacitatea de a utiliza în siguranță piscină.
- Când se utilizează învelitori pentru piscină, scoateți-le complet de pe suprafața apei înainte de a intra în piscină.
- Protejați ocupanții piscinei de bolile legate de apă, menținând apa din piscină tratată și practicând o igienă bună. Consultați instrucțiunile de tratare a apei din manualul de utilizare.
- Depozitați substanțele chimice (de exemplu, produse de tratare a apei, produse de curățare sau dezinfecție) la îndemâna copiilor.
- Semnalizarea trebuie afișată într-o poziție proeminentă la 2 m de piscină.
- Scările amovibile vor fi așezate pe o suprafață orizontală.

AVERTISMENT :

Fiecare aparat electric alimentat în 220 V trebuie să fie amplasat la cel puțin 3,50 m de marginea piscinei. Echipamentul trebuie conectat la o tensiune, cu conexiune la pământ, protejată de un dispozitiv de curent rezidual (RCD) cu un curent de funcționare rezidual nominal care să nu depășească 30 mA. Citiți cu atenție instrucțiunile și păstrați-le pentru referințe viitoare.

DACĂ AȚI ORICE PROBLEMĂ,
CONTACTAȚI-NE

web: www.grepool.com/en/aftersales



SÄKERHETS RÅD

Läs noga, förstå och följ all information i denna bruksanvisning innan du installerar och använder poolen. Dessa varningar, instruktioner och säkerhetsriktlinjer tar upp några vanliga risker med vattenrekreation, men de kan inte täcka alla risker och faror i alla fall. Var alltid försiktig, sunt förnuft och god bedömning när du gillar vattenaktiviteter. Spara denna information för framtida användning.

Icke simmare säkerhet

Kontinuerlig, aktiv och vaksam övervakning av svaga simmare och icke-simmare av en kompetent vuxen krävs alltid (kom ihåg att barn under fem år är i högsta risk för drunkning).
- Utse en kompetent vuxen att övervaka poolen varje gång den används.
- Svaga simmare eller icke-simmare bör bära personlig skyddsutrustning när du använder poolen.
- När poolen inte används eller utan tillsyn ska du ta bort alla leksaker från poolen och dess omgivning för att undvika att locka barn till poolen.

Säkerhetsanordningar

- Det rekommenderas att installera en barriär (och säkra alla dörrar och fönster, där så är tillämpligt) för att förhindra obehörig tillgång till poolen.
- Barriärer, poolöverdrag, poolalarm eller liknande säkerhetsanordningar är användbara hjälpmedel, men

Säkerhetsutrustning

- Uppmuntra alla användare, särskilt barn att lära sig simma
- Lär dig grundläggande livsstöd (Hjärt-lungräddning - HLR) och uppdatera denna kunskap regelbundet.

Säker användning av poolen

- Encourage all users especially children to learn how to swim
- Learn Basic Life Support (Cardiopulmonary Resuscitation - CPR) and refresh this knowledge regularly. This can make a life-saving difference in the event of an emergency.

Detta kan bli en livräddande skillnad i en nödsituation.

- Instruera alla användare av poolen, inklusive barn, vad de ska göra i en nödsituation
- Dyk aldrig ner i en grund vattenmassa. Detta kan leda till allvarlig personskada eller dödsfall.
- Använd inte poolen när du använder alkohol eller mediciner som kan försämra din förmåga att använda poolen på ett säkert sätt.
- När poolöverdrag används ska du ta bort dem helt från vattenytan innan du går in i poolen.
- Skydda poolens användare från vattenrelaterade sjukdomar genom att hålla poolens vatten behandlat och utöva god hygien. Se riktlinjerna för vattenrening i användarhandboken.
- Förvara kemikalier (t.ex. vattenbehandling, rengörings- eller desinfektionsprodukter) utom räckhåll för barn.
- Skyltar ska visas på en framträdande plats inom 2 m från poolen.
- Avtagbara stegar ska placeras på en horisontell yta.

WARNING:

Varje elektrisk apparat med 220 V måste placeras minst 3,50 m från poolens kant. Utrustningen ska anslutas till en spänning, med jordanslutning, skyddad av en jordfelsbrytare (RCD) med en nominell restström som inte överstiger 30 mA.

Läs instruktionerna noggrant och förvara för framtida referens.

OM DU HAR NÅGOT PROBLEM,
KONTAKTA OSS !

web: www.grepool.com/en/aftersales

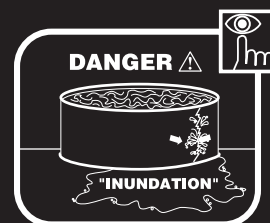
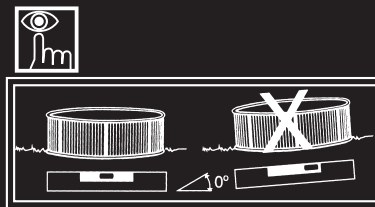

EN

COMPONENTS

Draw and classify all components included before assembly. It's time to assemble the ladder and the pump, follow the respective instructions. Kits with missing parts will be covered by the warranty only if reported to the after-sales service within 15 days as from the date of purchase of the swimming pool. In order to avoid any possible injury all swimming pool walking entrance must be regularly checked.

PL

ELEMENTY BASENU

Przed montażem wyciągnij z opakowania i pogrupuj wszystkie elementy wchodzące w skład zestawu. Najpierw zmontujemy drabinkę i pompę – postępuj zgodnie z odpowiednimi instrukcjami. Zestawy z brakującymi częściami będą objęte gwarancją tylko wtedy, gdy zostaną zgłoszone do serwisu posprzedażowego w ciągu 15 dni od daty zakupu basenu. Aby uniknąć ewentualnych obrażeń, wszystkie wejścia do basenu muszą być regularnie sprawdzane.

CS

COMPONENTS

Draw and classify all components included before assembly. It's time to assemble the ladder and the pump, follow the respective instructions. Kits with missing parts will be covered by the warranty only if reported to the after-sales service within 15 days as from the date of purchase of the swimming pool. In order to avoid any possible injury all swimming pool walking entrance must be regularly checked.

SK

COMPONENTS

Draw and classify all components included before assembly. It's time to assemble the ladder and the pump, follow the respective instructions. Kits with missing parts will be covered by the warranty only if reported to the after-sales service within 15 days as from the date of purchase of the swimming pool. In order to avoid any possible injury all swimming pool walking entrance must be regularly checked.

RO

COMPONENTE

Scoateți și clasificați toate componentele incluse înainte de asamblare. Este timpul să asamblați scara și pompa, urmați instrucțiunile respective. Kituri cu piese lipsă vor fi acoperite de garanție numai dacă sunt raportate serviciului post-vânzare în termen de 15 zile de la data achiziționării piscinei. Pentru a evita orice posibil rănire, intrarea pe jos a piscinei trebuie verificată în mod regulat.

SV

KOMPONENTER

Rita och klassificera alla komponenter som ingår före montering. Det är dags att montera stegen och pumpen, följ respektive instruktioner. Kit med saknade delar täcks endast av garantin om de rapporteras till kundservice inom 15 dagar från inköpsdatumet för poolen. För att undvika eventuella skador måste alla entréer till poolen regelbundet kontrolleras.

EN

COMPONENTS

PL

ELEMENTY

CS

COMPONENTS

SK

COMPONENTS



RO



COMPONENTE

SV

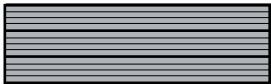
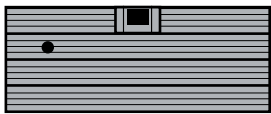
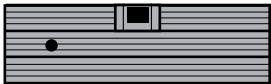
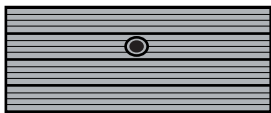
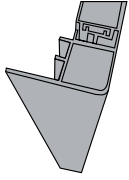
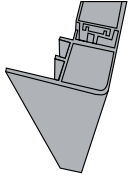
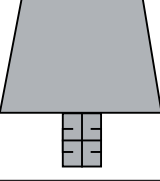
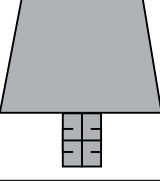
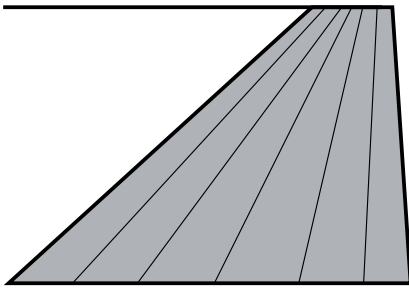
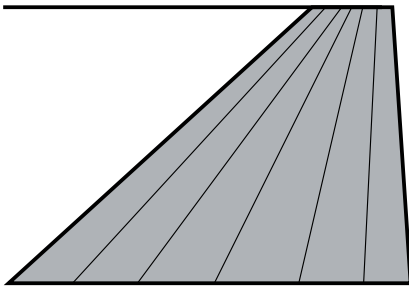
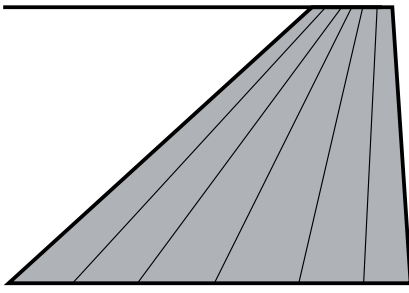
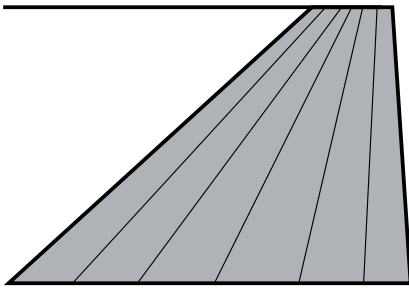
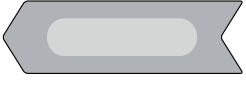
KOMPONENTER

- EN** Locate the model of your swimming pool in the following table and verify that the number of UNITS within each box or container matches this table (*for the kits).
- PL** Znajdź model swojego basenu w poniższej tabeli i sprawdź, czy liczba CZĘŚCI w każdym pudełku lub pojemniku jest zgodna z tą tabelą (*w przypadku zestawów).
- CS** Locate the model of your swimming pool in the following table and verify that the number of UNITS within each box or container matches this table (*for the kits).
- SK** Locate the model of your swimming pool in the following table and verify that the number of UNITS within each box or container matches this table (*for the kits).
- RO** Localizați modelul piscinei dvs. în tabelul următor și verificați dacă numărul de UNITĂȚI din fiecare cutie sau container se potrivește cu acest tabel (*pentru truse).
- SV** Leta reda på modellen för din pool i följande tabell och kontrollera att antalet ENHETER i varje låda eller behållare matchar denna tabell (* för satserna).

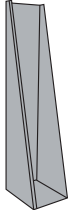
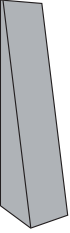
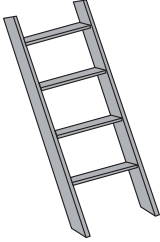
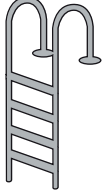
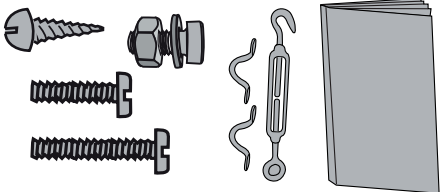
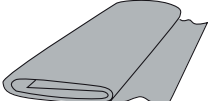
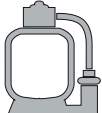
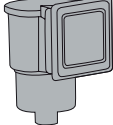
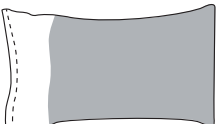
| REF | IMAGE | KPCOR60 | KPCOR60L | KPCOR46 | KPCOR28 | KPCOR2814 |
|----------------|---|---------|----------|---------|---------|-----------|
| PNCOMRF331400 |  | 11 | 10 | 9 | - | - |
| PNCOMRF140090 |  | - | - | - | 7 | 5 |
| PNCORF331400SK |  | 1 | 1 | 1 | - | - |
| PNCOMRF14009SK |  | - | - | - | 1 | 1 |
| PNCOMRFLD1400 |  | - | 1 | - | - | - |
| PVALM12101090 |  | 4 | 4 | 4 | - | - |
| PVAL9001090 |  | - | - | - | 4 | 4 |
| PVALM1210180 |  | 8 | 8 | 6 | - | - |
| PVAL900180 |  | - | - | - | 4 | 2 |
| PLYCOMP9045 |  | 6 | 6 | 6 | 6 | 2 |
| PLYCOMP9045SK |  | 2 | 2 | 2 | 2 | - |
| PLYCOMP45SK |  | - | - | - | - | 1 |
| PLYCOMP90 |  | 4 | 4 | 2 | - | - |
| ANG90 |  | 4 | 4 | 4 | 4 | 4 |
| ANG60180 |  | 8 | 8 | 6 | 4 | 2 |

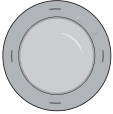
| REF | IMAGE | KPCOR60 | KPCOR60L | KPCOR46 | KPCOR28 | KPCOR2814 |
|--|---|---------|----------|---------|---------|-----------|
| SABOT |  | 8 | 8 | 6 | 4 | 2 |
| SABOTCOVER |  | 8 | 8 | 6 | 4 | 2 |
| ETCOMP ETCOMP90 |  | 1 | 1 | 1 | 1 | 1 |
| AR1174CO AR1173CO |  | 1 | 1 | 1 | 1 | 1 |
| KITENCOR46 KITENCOR2814 KITENVCOR60 (L) KITENVCOR28 |  | 1 | 1 | 1 | 1 | 1 |
| LINER |  | 1 | 1 | 1 | 1 | 1 |
| FILTER |  | 1 | 1 | 1 | 1 | 1 |
| SK101G |  | 1 | 1 | 1 | 1 | 1 |
| SILEX |  | 2 | 2 | 1 | 1 | 1 |
| MPROV |  | 1 | 1 | 1 | 1 | 1 |
| PLWPB |  | - | 1 | - | - | - |

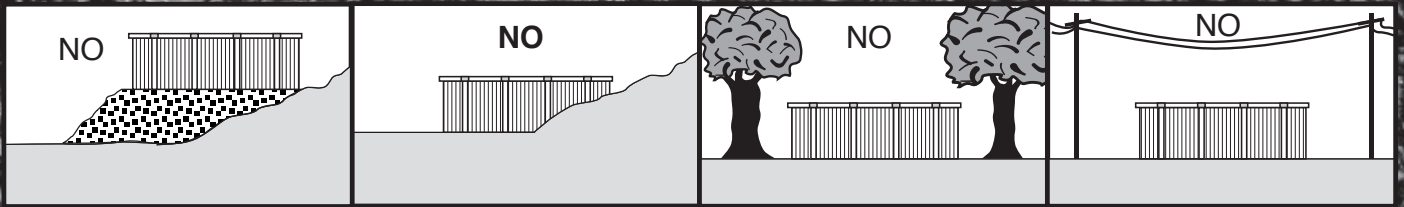

3

- EN PREPARATION OF THE SITE
- PL PRZYGOTOWANIE TERENU
- CS PREPARATION OF THE SITE
- SK PREPARATION OF THE SITE
- RO PREGĂTIREA SITULUI
- SV FÖRBEREDELSE AV PLATSEN

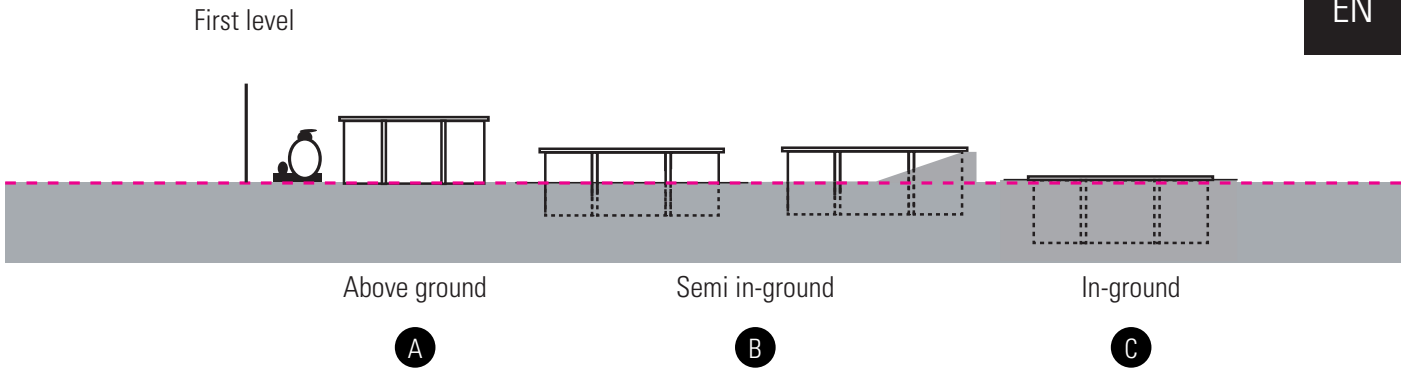

This is a determining stage in the construction of your pool. Certain works performed in situ, like the preparation of the land, the concrete slab, the draining... could need the intervention of professionals that will suggest the most adequate solutions.

Select the ideal location, in the sunniest spot possible, taking into account the local regulations (distance from the paths, public rights of way, networks...) and the landscaping after installing the pool.

Your pool can be installed in these three ways: A-B-C

Try to not install your pool on recently filled land or unstable land. Whatever type of installation you choose, you should excavate and prepare the land for levelling.

Attention: in the case that the land is sloping, you need to excavate it for levelling. Do not add soil to level it.

The installation should be using a concrete foundation slab, at least 15 centimetres thick. The pool is assembled after the concrete foundation slab has completely dried (3 weeks). The filter group should be located below the level of the pool and ideally at the floor level of the pool.

PARTIAL OR COMPLETELY IN-GROUND INSTALLATION

According to the nature of the land, you should install a peripheral drainage and connect it to a decompression well. The well will be excavated before the construction of the pool to avoid that the excavations fill with water during the works. It should be near the pool, a few centimetres lower than the deepest point of the same and reach up to the surface. The decompression well is located at the most humid point. It acts as an overflow in the case of water infiltrations or clay soil, starting from the fact that water rises quicker through a tube than through the soil.

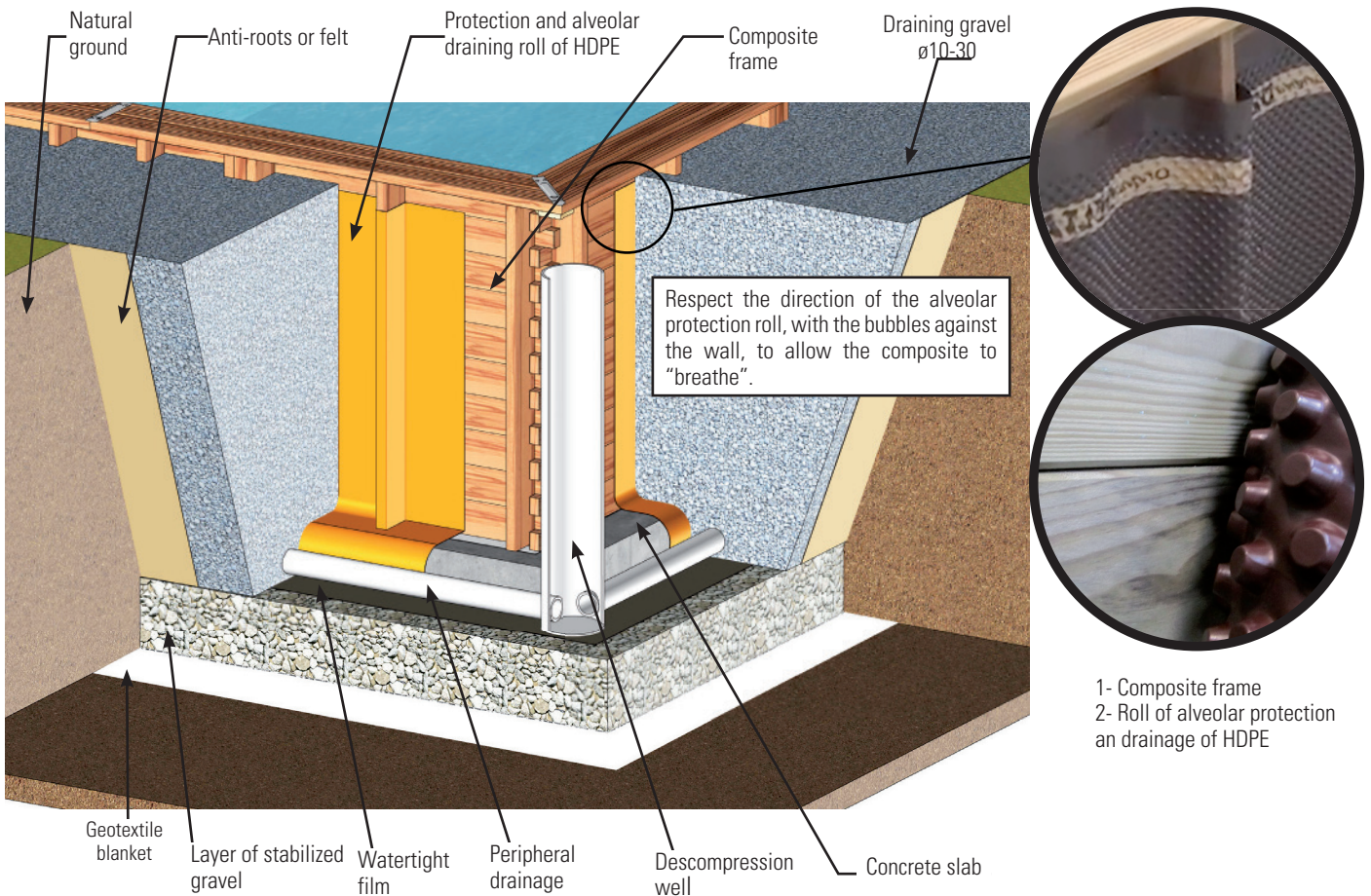

Pierwszy poziom

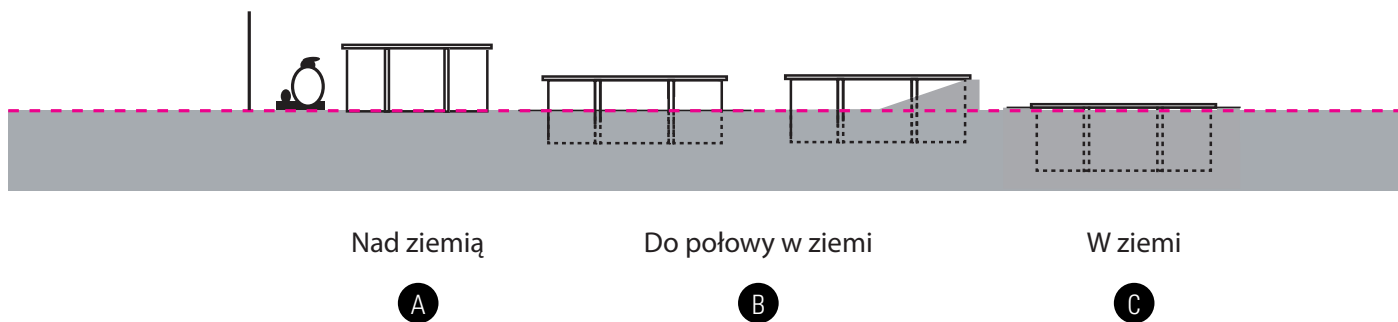

Nad ziemią

A

Do połowy w ziemi

B

W ziemi

C

Jest to kluczowy etap montażu Twojego basenu. Niektóre prace wykonywane na miejscu, takie jak: przygotowanie terenu, płyta betonowa lub drenaż, mogą wymagać interwencji profesjonalistów, którzy zaproponują najodpowiedniejsze rozwiązania.

Wybierz idealną lokalizację, w najbardziej nasłonecznionym miejscu, mając na względzie lokalne przepisy (odnośnie odległości od ścieżek, dróg publicznych, sieci itd.) oraz zagospodarowanie terenu po zainstalowaniu basenu.

Twój basen może być zainstalowany na trzy sposoby: A-B-C

Staraj się nie instalować basenu na niedawno wypełnionej ziemi lub niestabilnym gruncie. Niezależnie od wybranego sposobu instalacji, należy wykopać i przygotować teren do wyrównania.

Uwaga: w przypadku, gdy teren jest nachylony, należy go wykopać w celu wyrównania. Nie należy dodawać ziemi w celu wyrównania terenu.

- W przypadku montażu basenu nad ziemią można użyć podsypki piaskowej, albo płyty betonowej. Jeśli wybierzesz podsypkę, użyj drobnego i czystego piasku, w przeciwnym razie liner może ulec zabarwieniu glonami.
- W przypadku, gdy basen montowany jest do połowy lub całkowicie w ziemi, instalacja powinna zostać przeprowadzona na betonowej płycie fundamentowej. Jeżeli używana jest betonowa płyta fundamentowa, powinna ona mieć grubość co najmniej 15 cm. Basen należy zamontować po całkowitym wyschnięciu betonowej płyty fundamentowej (3 tygodnie). Filtry powinny zostać umieszczone poniżej poziomu basenu, a najlepiej na poziomie jego podłoża.

CZĘŚCIOWA LUB CAŁKOWITA INSTALACJA W ZIEMI

Zgodnie z rodzajem terenu, należy zainstalować drenaż obwodowy i połączyć go ze studnią dekompresyjną. Studnia zostanie wykopana przed budową basenu, aby otwór w ziemi nie wypełnił się wodą podczas prac. Powinna ona znajdować się w pobliżu basenu, kilka centymetrów niżej niż jego najgłębszy punkt i sięgać aż do powierzchni. Studnia dekompresyjna znajduje się w najbardziej wilgotnym miejscu. Działa ona jak przelew w przypadku infiltracji wody lub gliniastej gleby, ponieważ woda przepływa szybciej przez rurę niż przez glebę.

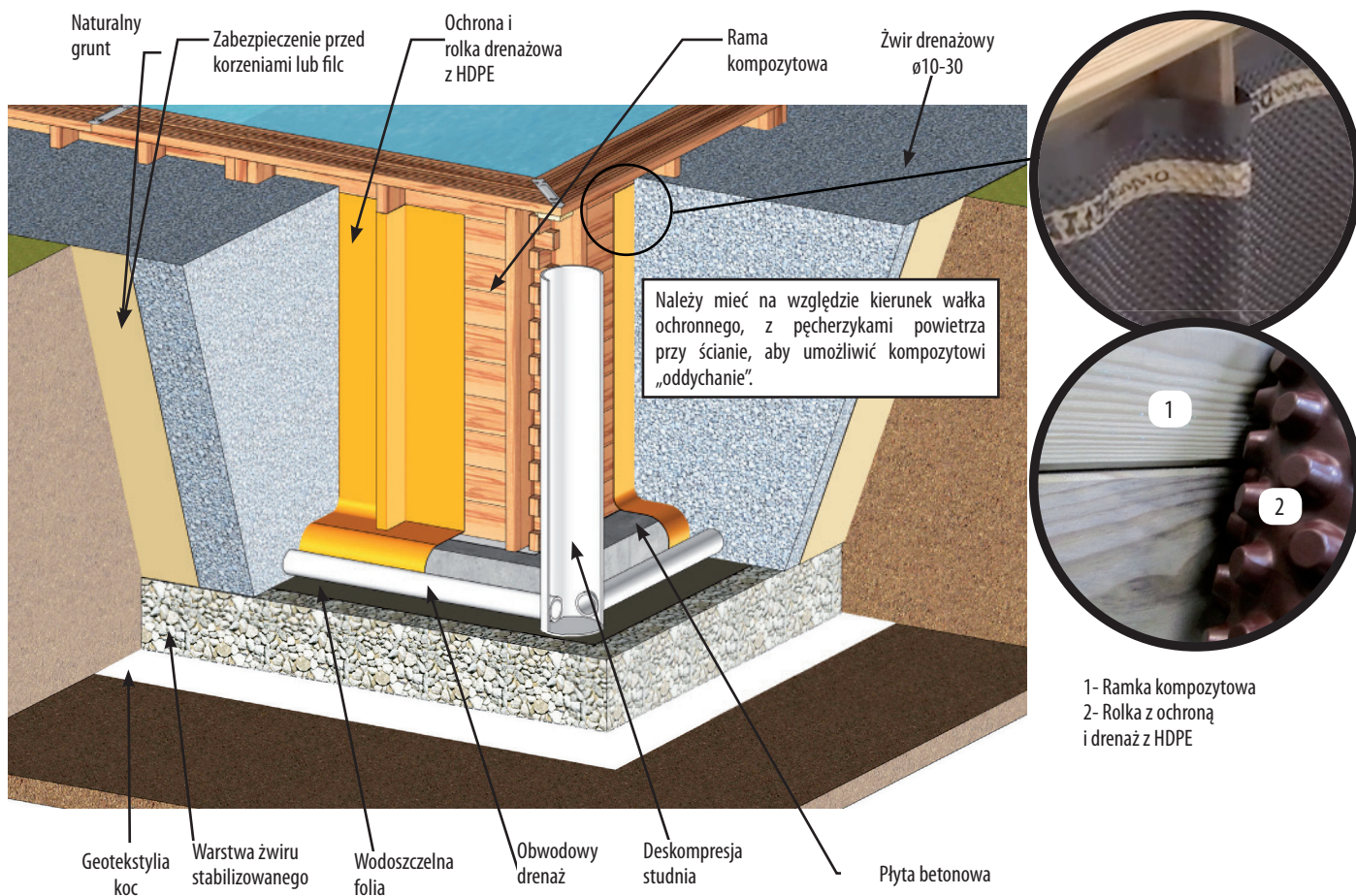

First level

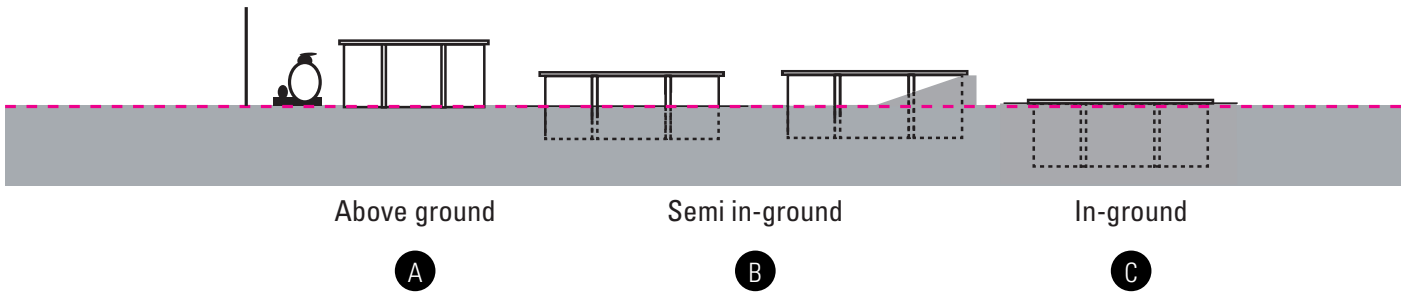

Above ground

A

Semi in-ground

B

In-ground

C

This is a determining stage in the construction of your pool. Certain works performed in situ, like the preparation of the land, the concrete slab, the draining... could need the intervention of professionals that will suggest the most adequate solutions.

Select the ideal location, in the sunniest spot possible, taking into account the local regulations (distance from the paths, public rights of way, networks...) and the landscaping after installing the pool.

Your pool can be installed in these three ways: A-B-C

Try to not install your pool on recently filled land or unstable land. Whatever type of installation you choose, you should excavate and prepare the land for levelling.

Attention: in the case that the land is sloping, you need to excavate it for levelling. Do not add soil to level it.

- In the case of assembling your pool above ground, you can use either a bed of sand or a concrete slab. If you choose the bed of sand, use fine and clean sand, otherwise you could stain the liner due to there being algae.
- In the case that the pool is semi in-ground or completely in-ground, the installation should be using a concrete foundation slab. If a foundation concrete slab is used this should be at least 15 centimetres thick. The pool is assembled after the concrete foundation slab has completely dried (3 weeks). The filter group should be located below the level of the pool and ideally at the floor level of the pool.

PARTIAL OR COMPLETELY IN-GROUND INSTALLATION

According to the nature of the land, you should install a peripheral drainage and connect it to a decompression well. The well will be excavated before the construction of the pool to avoid that the excavations fill with water during the works. It should be near the pool, a few centimetres lower than the deepest point of the same and reach up to the surface. The decompression well is located at the most humid point. It acts as an overflow in the case of water infiltrations or clay soil, starting from the fact that water rises quicker through a tube than through the soil.

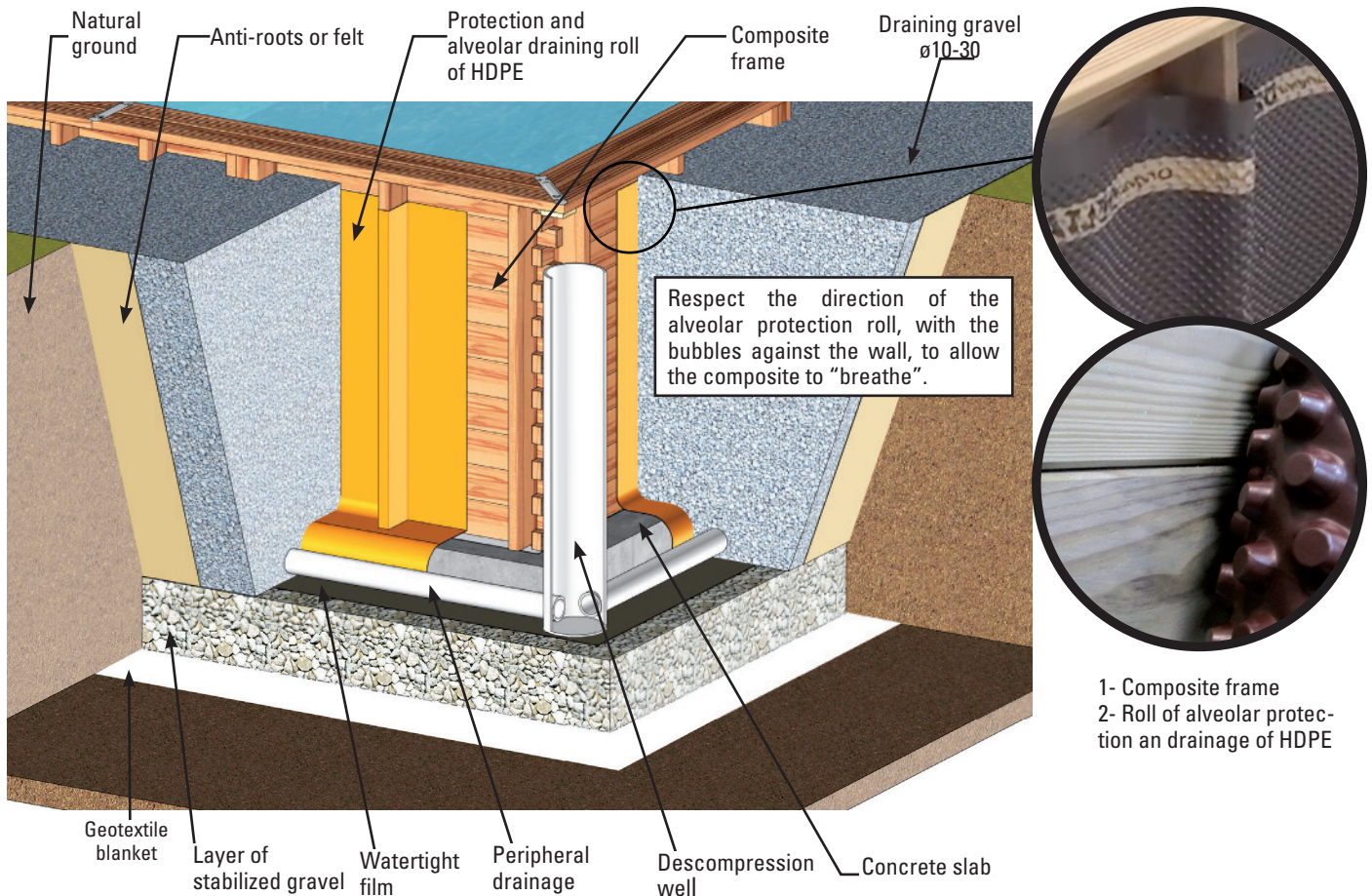

- 1- Composite frame
- 2- Roll of alveolar protection and drainage of HDPE

First level

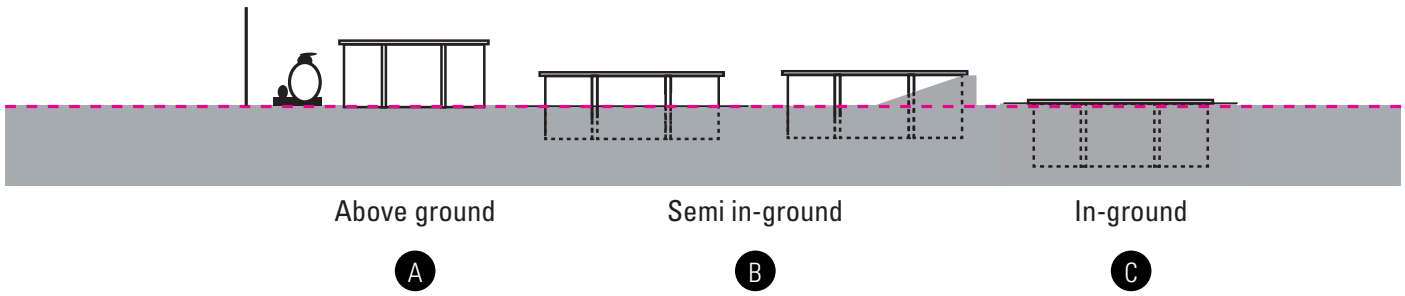

This is a determining stage in the construction of your pool. Certain works performed in situ, like the preparation of the land, the concrete slab, the draining... could need the intervention of professionals that will suggest the most adequate solutions.

Select the ideal location, in the sunniest spot possible, taking into account the local regulations (distance from the paths, public rights of way, networks...) and the landscaping after installing the pool.

Your pool can be installed in these three ways: A-B-C

Try to not install your pool on recently filled land or unstable land. Whatever type of installation you choose, you should excavate and prepare the land for levelling.

Attention: in the case that the land is sloping, you need to excavate it for levelling. Do not add soil to level it.

- In the case of assembling your pool above ground, you can use either a bed of sand or a concrete slab. If you choose the bed of sand, use fine and clean sand, otherwise you could stain the liner due to there being algae.
- In the case that the pool is semi in-ground or completely in-ground, the installation should be using a concrete foundation slab. If a foundation concrete slab is used this should be at least 15 centimetres thick. The pool is assembled after the concrete foundation slab has completely dried (3 weeks). The filter group should be located below the level of the pool and ideally at the floor level of the pool.

PARTIAL OR COMPLETELY IN-GROUND INSTALLATION

According to the nature of the land, you should install a peripheral drainage and connect it to a decompression well. The well will be excavated before the construction of the pool to avoid that the excavations fill with water during the works. It should be near the pool, a few centimetres lower than the deepest point of the same and reach up to the surface. The decompression well is located at the most humid point. It acts as an overflow in the case of water infiltrations or clay soil, starting from the fact that water rises quicker through a tube than through the soil.

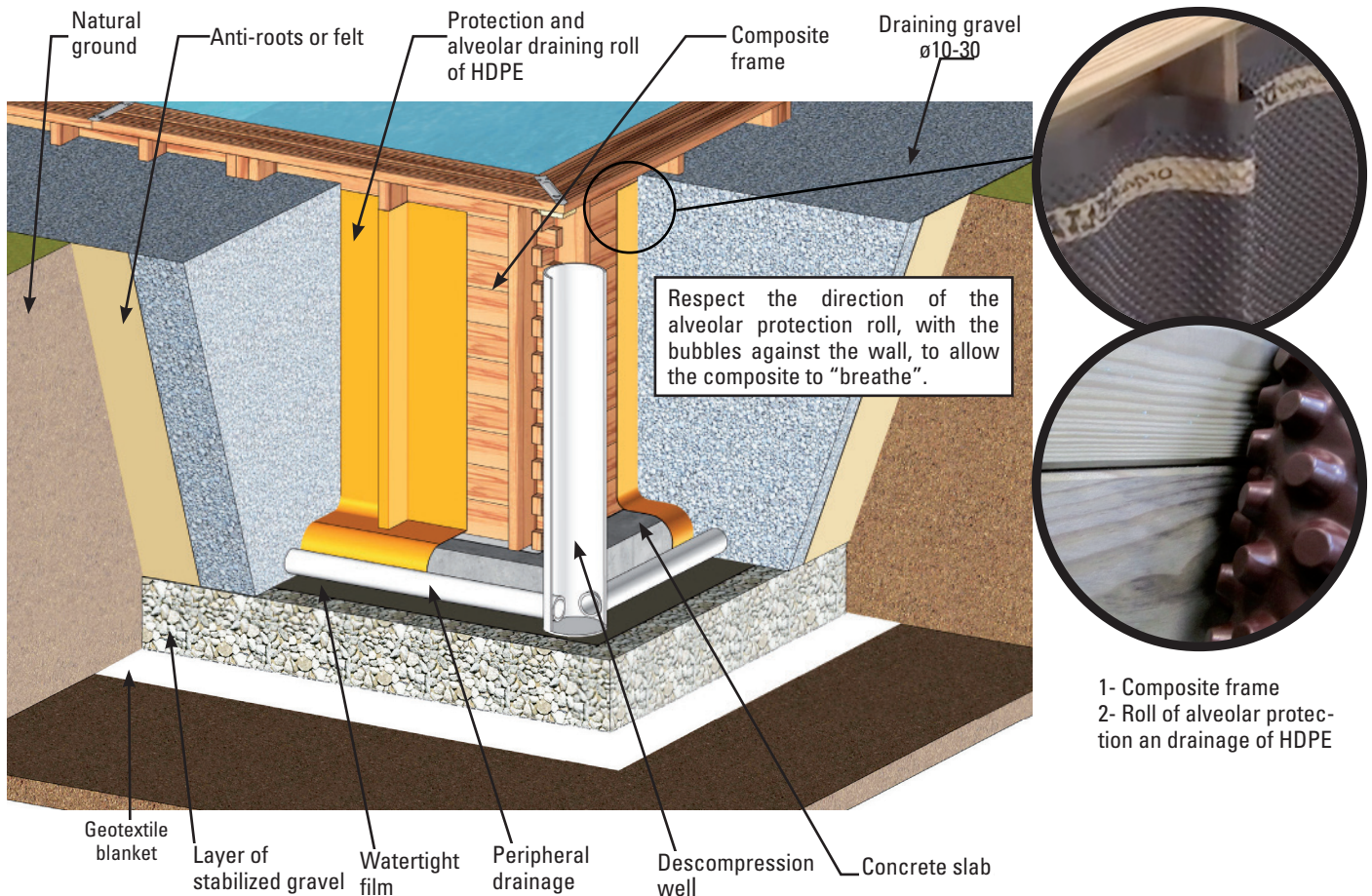

- 1- Composite frame
- 2- Roll of alveolar protection and drainage of HDPE

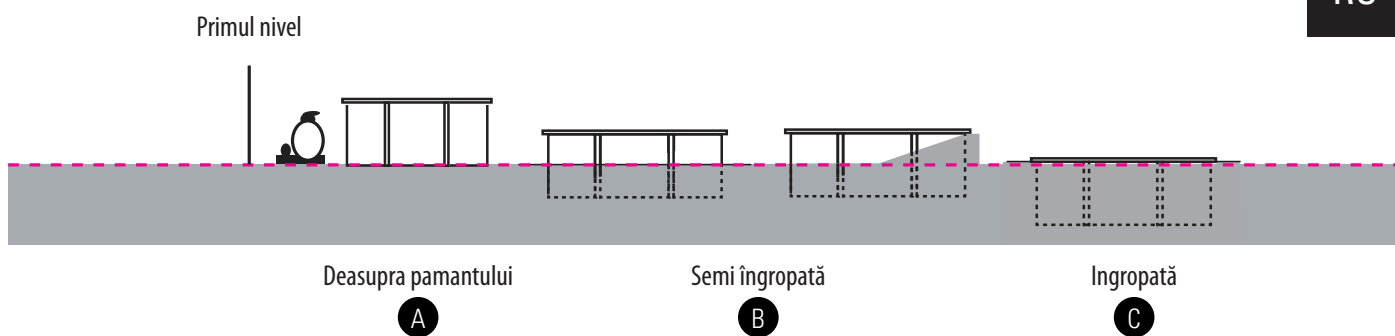

Aceasta este o etapă determinantă în construcția piscinei dvs. Anumite lucrări efectuate in situ, cum ar fi pregătirea terenului, placa de beton, drenarea ... ar putea avea nevoie de intervenția specialiștilor care vor sugera cele mai adecvate soluții.

Selecționați locația ideală, în cel mai înșorit loc posibil, luând în considerare reglementările locale (distanța de la căi, drepturile de trecere publice, rețelele ...) și amenajarea teritoriului după instalarea piscinei.

Piscina dvs. poate fi instalată în aceste trei moduri: A-B-C

Încercați să nu vă instalați piscina pe terenuri umplute recent sau pe terenuri instabile. Indiferent de tipul de instalație pe care îl alegeți, ar trebui să excavați și să pregătiți terenul pentru nivelare.

Atenție: în cazul în care terenul este înclinat, trebuie să-l săpați pentru nivelare. Nu adăugați sol pentru a-l nivela.

- În cazul asamblării piscinei dvs. deasupra solului, puteți utiliza fie un pat de nisip, fie o placă de beton. Dacă alegeți patul de nisip, folosiți nisip fin și curat, altfel ați putea pata căptușeala din cauza existenței algelor.

- În cazul în care piscina este semi-în pământ sau complet în pământ, instalația ar trebui să utilizeze o placă de fundație din beton. Dacă se folosește o placă de beton pentru fundație, aceasta trebuie să aibă o grosime de cel puțin 15 centimetri. Piscina este asamblată după ce placa de fundație din beton s-a uscat complet (3 săptămâni). Grupul de filtrare trebuie amplasat sub nivelul piscinei și ideal la nivelul pardoselii piscinei.

INSTALAREA PARȚIALĂ SAU COMPLETĂ ÎN SOL

În funcție de natura terenului, ar trebui să instalați un drenaj periferic și să îl conectați la un puț de decompresie. Fântâna va fi excavată înainte de construirea bazinului pentru a evita ca săpăturile să se umple cu apă în timpul lucrărilor. Ar trebui să fie lângă piscină, cu câțiva centimetri mai jos decât cel mai adânc punct al aceleiași și să ajungă până la suprafață. Puțul de decompresie este situat în cel mai umed punct. Acționează ca un deversor în cazul infiltrațiilor de apă sau al solului argilos, pornind de la faptul că apa crește mai repede printr-un tub decât prin sol.

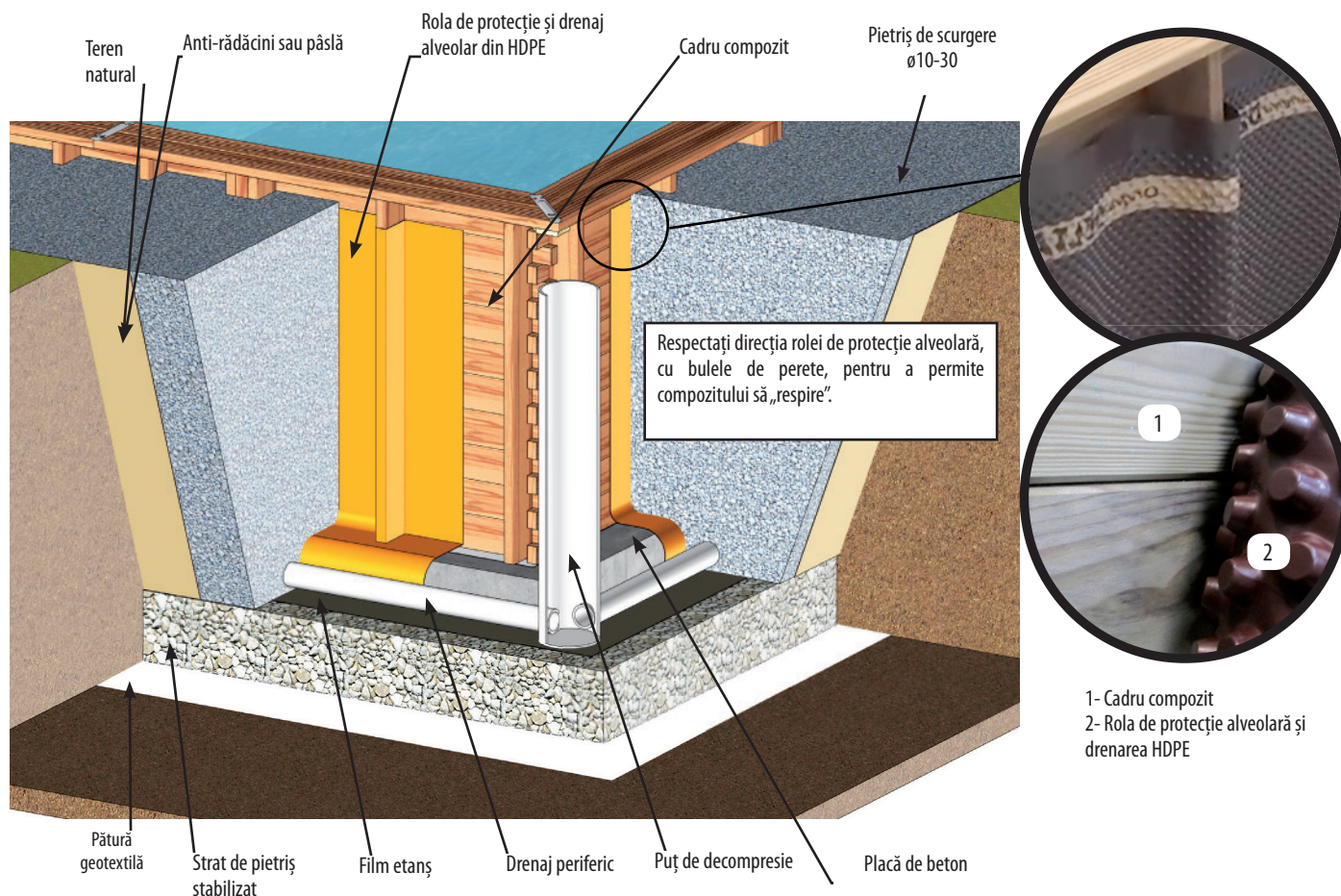

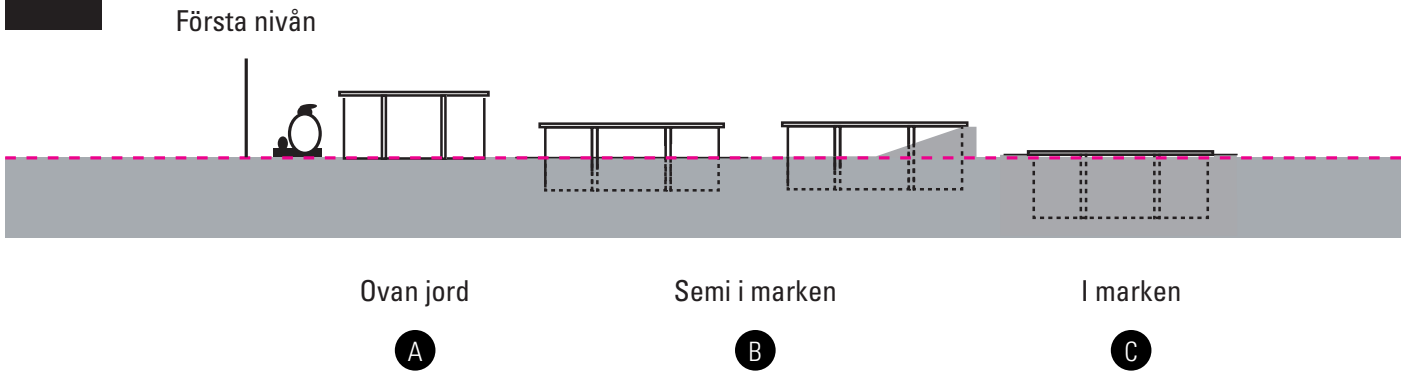

Detta är ett avgörande skede i byggandet av din pool. Vissa arbeten som utförs på plats, som förberedelse av marken, betongplattan, dräneringen ... kan behöva ingripande av proffs som kommer att föreslå de mest adekvata lösningarna. Välj den perfekta platsen, på den soligaste platsen, med hänsyn till de lokala bestämmelserna (avstånd från banor, allmänna rättigheter, nätverk ...) och landskapsarkitektur efter installationen av poolen.

Din pool kan installeras på följande tre sätt: ABC

Försök att inte installera din pool på nyligen fylld mark eller instabil mark. Oavsett vilken typ av installation du väljer, bör du gräva och förbereda marken för planering.

Observera: om marken är sluttande måste du gräva den för utjämning. Tillsätt inte jord för att jämna ut den.

- Vid montering av din pool över marken kan du använda antingen en sandbädd eller en betongplatta. Om du väljer sandbädden, använd fin och ren sand, annars kan du fläcka linern på grund av att det finns alger.
- Om poolen är halv i marken eller helt i marken ska installationen användas med en betongfundament. Om en grundbetongplatta används bör den vara minst 15 centimeter tjock. Poolen monteras efter att betongfundamentet har torkat helt (3 veckor). Filtergruppen ska placeras under poolnivån och helst på golvnivån i poolen.

PARTIELL ELLER HELT INSTALLATION I JORDEN

Enligt landets natur bör du installera en perifer dränering och ansluta den till en dekompressionsbrunn. Brunnen kommer att grävas innan poolen byggs för att undvika att utgrävningarna fylls med vatten under arbetet. Den ska vara nära poolen, några centimeter lägre än densamma djupaste punkt och nå upp till ytan. Dekompressionsbrunnen ligger vid den mest fuktiga punkten. Det fungerar som ett överflöde vid vatteninfiltrationer eller lerjord, med utgångspunkt från det faktum att vatten stiger snabbare genom ett rör än genom jorden.

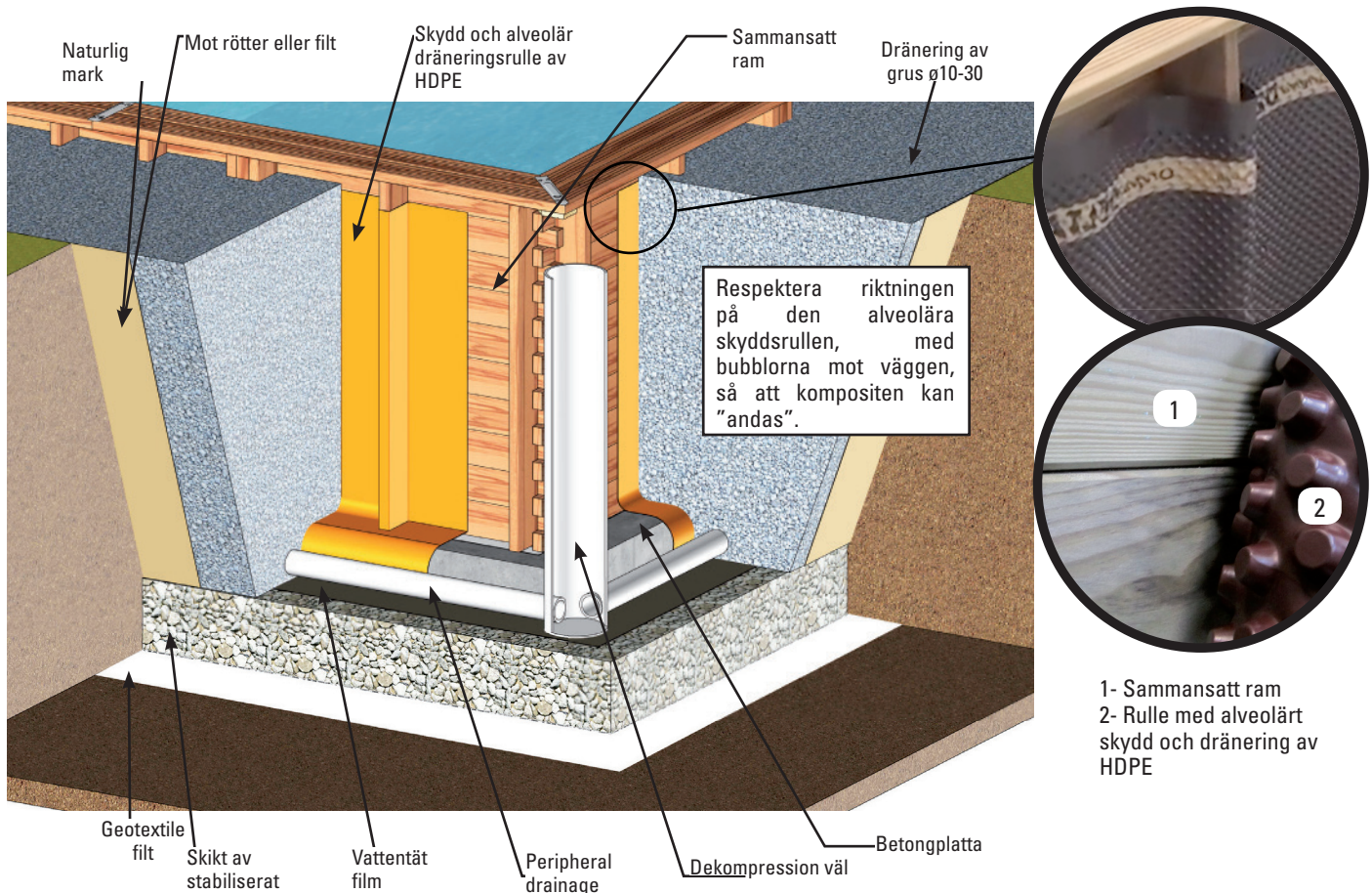

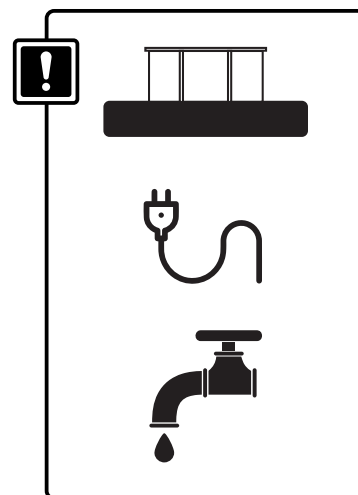
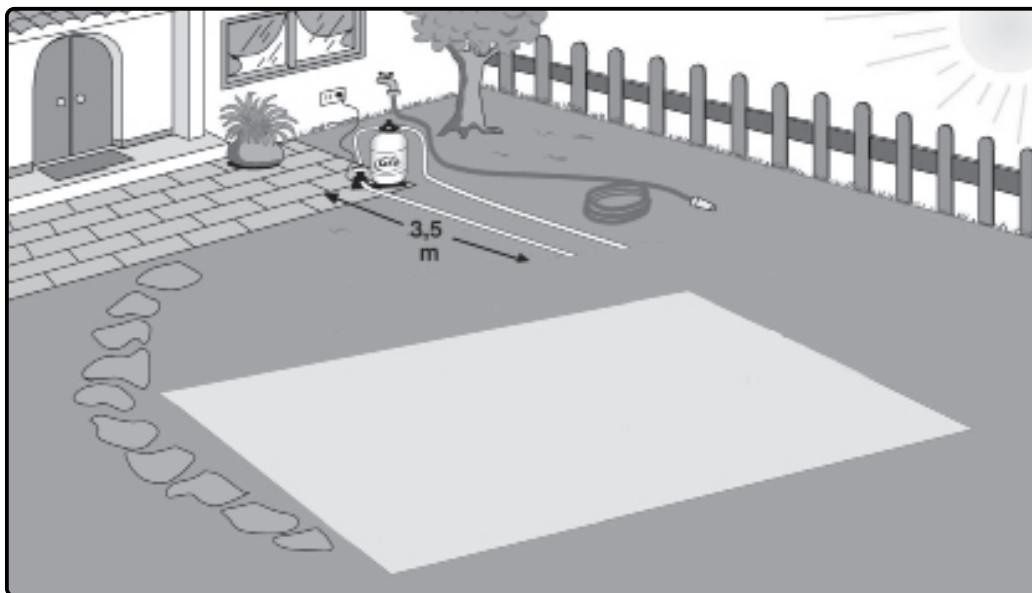

Installation place: Our pools are designed to be erected above ground and for an outdoor family use. The ground has to be firm, flat and perfectly horizontal. Remember: 1000 lts of water = 1 m³ = 1000 Kgs.

Advices to chose the best location for your pool:

- Select a place where you'll have to realize the least excavation to levelled the ground. • Non easily inundated area in case of rain. • Where there is not any underground connection (water, gaz, electricity,...). • Do not install it underneath electric line. • Protected from wind and without any trees because the pollen and the leaves make the pool dirty. • Sunny area, where the most sun is during the morning. • Close to a water and power supply and drainage system. UNACCEPTABLE LOCATION: Sloping, uneven ground. Sandy, rocky or soggy ground.

Miejsce montażu: Nasze baseny przeznaczone są do montażu na powierzchni ziemi, do użytku rodzinnego na świeżym powietrzu. Podłoże musi być twarde, płaskie i idealnie poziome. Pamiętaj: 1000 l wody = 1 m³ = 1000 kg.

Zalecenia dotyczące wyboru najlepszego miejsca dla Twojego basenu:

- Wybierz miejsce wymagające minimalnego wykopu w celu wyrównania terenu. • Wybierz miejsce nieulegające zalaniu w przypadku deszczu. • Wybierz miejsce bez żadnych podziemnych połączeń (woda, gaz, prąd itd.). • Nie instaluj basenu pod linią wysokiego napięcia. • Wybierz miejsce chroniące przed wiatrem i z dala od drzew, ponieważ pyłki kwiatów i liście brudzą wodę w basenie. • Wybierz słoneczne miejsce, gdzie najczęściej słońca jest w godzinach porannych. • Wybierz miejsce blisko sieci wodociągowej i energetycznej oraz systemu odprowadzania wody. NIEDOPUSZCZALNE MIEJSCE: Pochyłe i nierówne podłoże. Piaszczyste, skaliste lub podmokłe podłoże.

Installation place: Our pools are designed to be erected above ground and for an outdoor family use. The ground has to be firm, flat and perfectly horizontal. Remember: 1000 lts of water = 1 m³ = 1000 Kgs.

Advices to chose the best location for your pool:

- Select a place where you'll have to realize the least excavation to levelled the ground. • Non easily inundated area in case of rain. • Where there is not any underground connection (water, gaz, electricity,...). • Do not install it underneath electric line. • Protected from wind and without any trees because the pollen and the leaves make the pool dirty. • Sunny area, where the most sun is during the morning. • Close to a water and power supply and drainage system. UNACCEPTABLE LOCATION: Sloping, uneven ground. Sandy, rocky or soggy ground.

Installation place: Our pools are designed to be erected above ground and for an outdoor family use. The ground has to be firm, flat and perfectly horizontal. Remember: 1000 lts of water = 1 m³ = 1000 Kgs.

Advices to chose the best location for your pool:

- Select a place where you'll have to realize the least excavation to levelled the ground. • Non easily inundated area in case of rain. • Where there is not any underground connection (water, gaz, electricity,...). • Do not install it underneath electric line. • Protected from wind and without any trees because the pollen and the leaves make the pool dirty. • Sunny area, where the most sun is during the morning. • Close to a water and power supply and drainage system. UNACCEPTABLE LOCATION: Sloping, uneven ground. Sandy, rocky or soggy ground.

Loc de instalare: Piscinile noastre sunt proiectate pentru a fi ridicate deasupra solului și pentru o utilizare în familie în aer liber. Pământul trebuie să fie ferm, plat și perfect orizontal. **Amintiți-vă:** 1000 l de apă = 1 m³ = 1000 Kgs.

Sfaturi pentru a alege cea mai bună locație pentru piscina dvs.:

- Selectați un loc în care va trebui să țineți cea mai mică excavare pentru a nivela pământul. • Zona neinundabilă ușor în caz de ploaie. • Acolo unde nu există nicio conexiune subterană (apă, gaz, electricitate, ...). • Nu o instalați sub linia electrică. • Protejată de vânt și fără copaci, deoarece Polenul și frunzele murdăresc piscina. • Zona însorită, unde cel mai mult soare este dimineața. • Aproape de un sistem de alimentare cu apă și de drenaj. **LOCAȚIE INACCEPTABILĂ:** Teren înclinat, neuniform, sol nisipos, stâncos sau ud.

Installationsplats: Våra pooler är konstruerade för att uppföras över marken och för utomhusbruk för familjen. Marken måste vara fast, plan och perfekt horisontell. Kom ihåg: 1000 liter vatten = 1 m³ = 1000 kg.

- Råd för att välja den bästa platsen för din pool:**
- Välj en plats där du ska ha minst utgrävning för att plana marken. • Icke lättindikerat område vid regn. • Om det inte finns någon underjordisk anslutning (vatten, gas, el ...) • Installera inte den under en elektrisk ledning • Skydda mot vind och utan några träd sköta pollen och bladen gör poolen smutsig. • Soligt område, där det är mer sol under dagen. • Nära ett vatten- och strömförsörjnings- och avloppssystem.

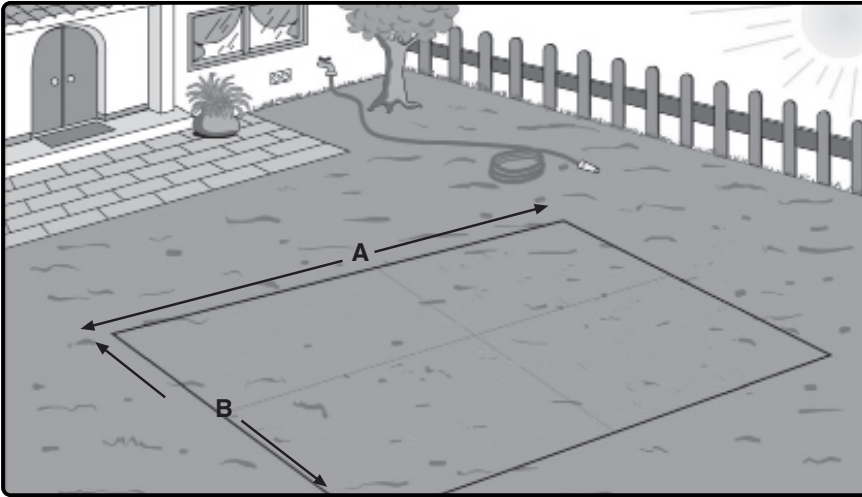

| | | |
|---|---------------------|----------------|
| ! | KPCOR60 KPCOR60L | KPCOR46 |
| | 800cm 520cm | 660cm 520cm |
| | KPCOR28 | KPCOR2814 |
| | 520cm 520cm | 520cm 380cm |

- EN Mark the installation area:** Identify your pool model in this table for the dimensions needed for installation. To mark the ground, use wooden stakes, a screwdriver, funnel or plastic bottle and flour or lime. It is essential to level the total surface necessary before the marking to ensure the correct pool installation. Check the table to mark the location of your pool, as centered as possible in the rectangle.
- PL Zaznacz obszar instalacji:** Sprawdź swój model basenu w tej tabeli, aby otrzymać wymiary potrzebne do instalacji. Oznacz obszar montażu za pomocą drewnianych palików, śrubokrętu, lejki, plastikowej butelki, mąki lub wapna. Przed oznaczeniem należy wyrównać całą niezbędną powierzchnię, aby zapewnić prawidłową instalację basenu. Sprawdź tabelę, aby zaznaczyć położenie swojego basenu, pamiętając o zachowaniu jego prostokątnego kształtu.
- CS Mark the installation area:** Identify your pool model in this table for the dimensions needed for installation. To mark the ground, use wooden stakes, a screwdriver, funnel or plastic bottle and flour or lime. It is essential to level the total surface necessary before the marking to ensure the correct pool installation. Check the table to mark the location of your pool, as centered as possible in the rectangle.
- SK Mark the installation area:** Identify your pool model in this table for the dimensions needed for installation. To mark the ground, use wooden stakes, a screwdriver, funnel or plastic bottle and flour or lime. It is essential to level the total surface necessary before the marking to ensure the correct pool installation. Check the table to mark the location of your pool, as centered as possible in the rectangle.
- RO Marcați zona de instalare:** Marcați zona de instalare: identificați modelul de piscină în acest tabel pentru dimensiunile necesare pentru instalare. Pentru a marca pământul, utilizați țărugi din lemn, o șurubelniță, pânle sau sticlă de plastic și făină sau var. Este esențial să se niveleze suprafața totală necesară înainte de marcare pentru a asigura instalarea corectă a piscinei. Verificați tabelul pentru a marca locația bazinului dvs., cât mai centrat posibil în dreptunghi.
- SV Markera installationsområdet:** Identifiera din poolmodell i den här tabellen för de dimensioner som behövs för installationen. För att markera marken, använd träpinnar, en skruvmejsel, tratt eller plastflaska och mjöl eller kalk. Det är viktigt att planera den totala ytan som krävs innan markeringen för att säkerställa korrekt poolinstallation. Kontrollera tabellen för att markera din pool, så centrerad som möjligt i rektangeln.

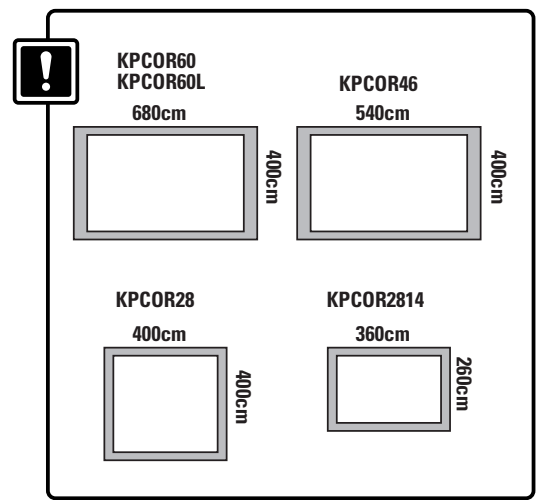
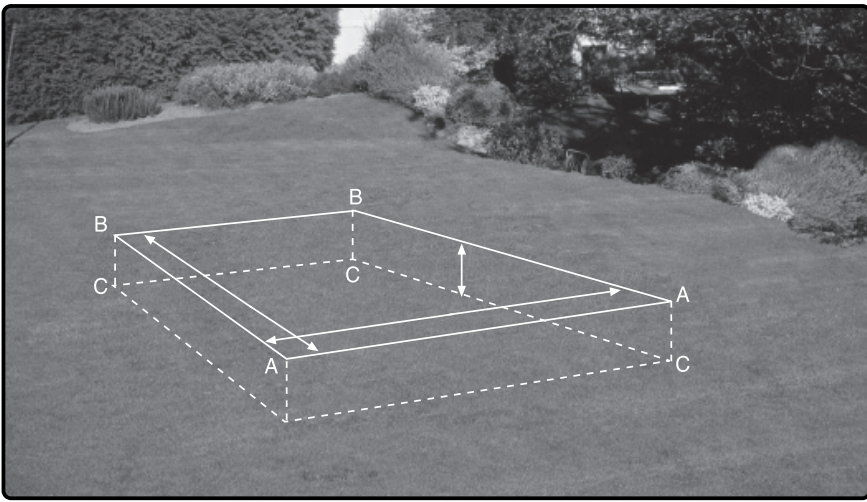

EN INSTALLATION OF THE SWIMMING POOL IN CONCRETE SLAB

- Prior to installing the pool, you need to create a reinforced concrete slab which is a minimum of 350 Kg/m³ and 15 cm thick. It must be a perfectly flat and horizontal slab.
- Perform a small dig, according to the measurements on the table.

PL MONTAŻ BASENU NA PŁYTCY BETONOWEJ

- Przed przystąpieniem do montażu basenu należy wykonać płytę betonową zbrojoną o minimalnej gęstości 350 kg/m³ i grubości 15 cm. Musi to być idealnie płaska i pozioma płyta.
- Wykonaj niewielki wykop, zgodnie z wymiarami podanymi w tabeli.

CS INSTALLATION OF THE SWIMMING POOL IN CONCRETE SLAB

- Prior to installing the pool, you need to create a reinforced concrete slab which is a minimum of 350 Kg/m³ and 15 cm thick. It must be a perfectly flat and horizontal slab.
- Perform a small dig, according to the measurements on the table.

SK INSTALLATION OF THE SWIMMING POOL IN CONCRETE SLAB

- Prior to installing the pool, you need to create a reinforced concrete slab which is a minimum of 350 Kg/m³ and 15 cm thick. It must be a perfectly flat and horizontal slab.
- Perform a small dig, according to the measurements on the table.

RO INSTALAREA PISCINEI ÎN PLACĂ DE BETON

- Înainte de instalarea piscinei, trebuie să construiți o placă de beton armat cu densitate minimă de 350 Kg/m³ și grosime de 15 cm. Trebuie să fie o placă perfect plană și orizontală.
- Executați o mică perforație, conform măsurilor din tabel.

SV INSTALLATION AV SWIMMINGPOOLEN PÅ BETONGPLATTA

- Innan du installerar poolen måste du skapa en armerad betongplatta som är minst 350 kg / m³ och 15 cm tjock. Det måste vara en helt platt och horisontell platta.
- Utför en liten grävning enligt måtten på bordet.

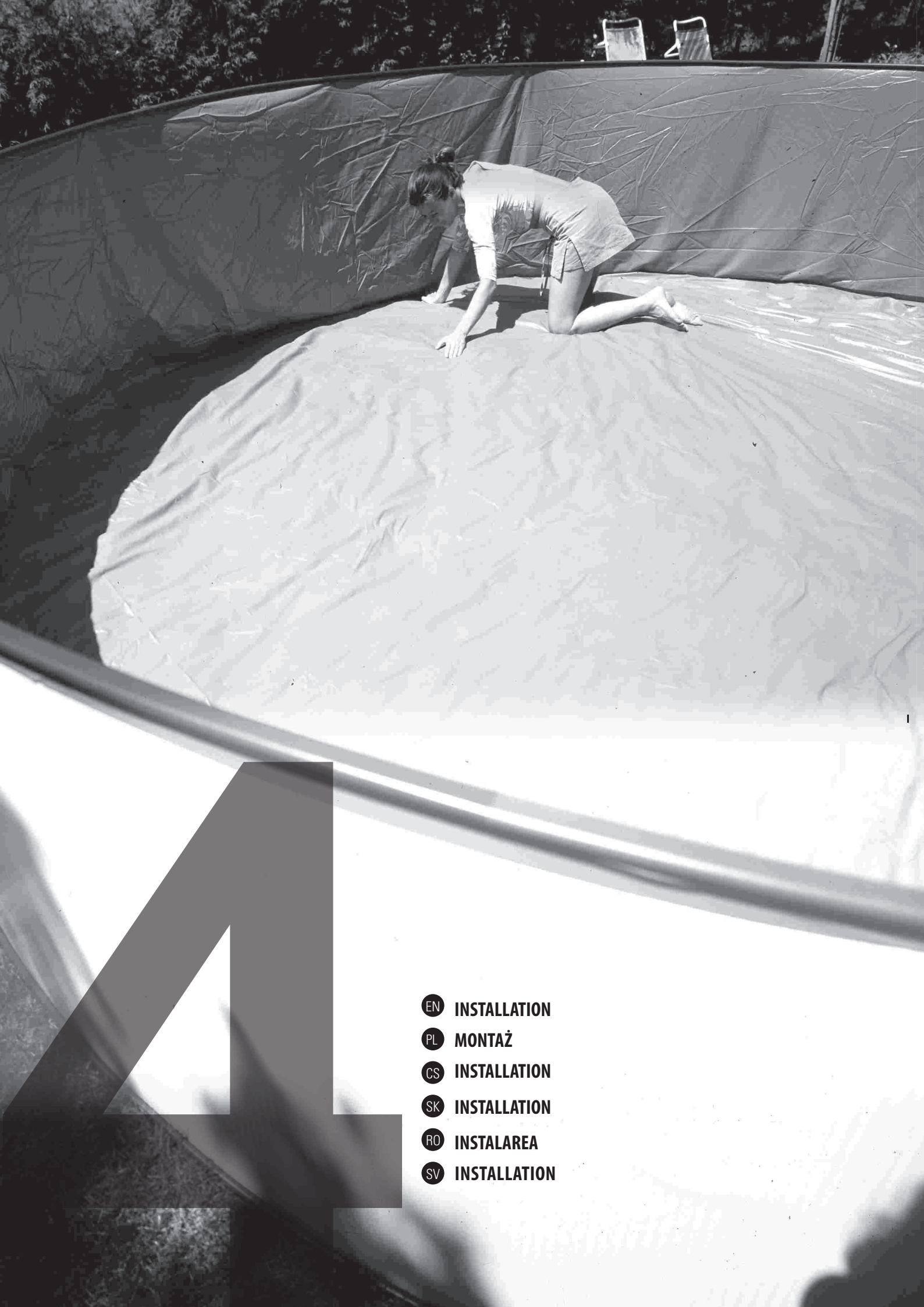

- EN INSTALLATION
- PL MONTAŻ
- CS INSTALLATION
- SK INSTALLATION
- RO INSTALAREA
- SV INSTALLATION

**KPCOR60
KPCOR60L**

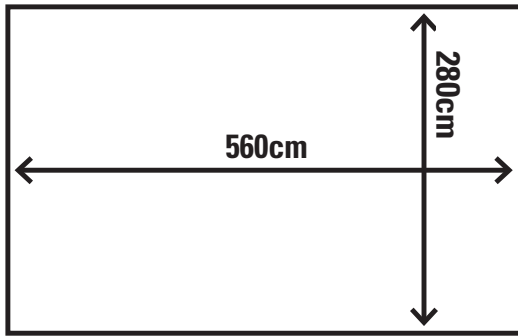

KPCOR46

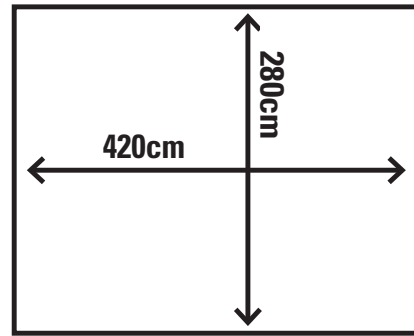

KPCOR28

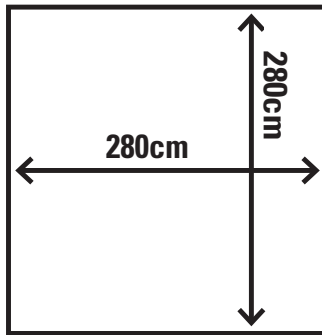

KPCOR2814

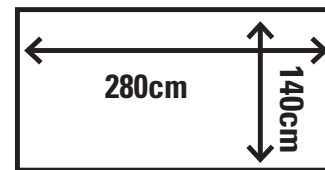

EN INTERIOR DIMENSIONS:

Once the floor is properly leveled, the ground will be marked with the lines where the inside face of the panels of the swimming pool will be supported.

It is time to check the measurements.

If not, the exercise needs to be performed again.

PL WYMIARY WEWNĘTRZNE:

Po odpowiednim wypoziomowaniu powierzchni na podłożu zostaną wyznaczone linie, na których będą opierać się wewnętrzne powierzchnie paneli basenu.

Następnie należy sprawdzić wymiary.

Jeśli nie są one prawidłowe, czynności należy wykonać ponownie.

CS INTERIOR DIMENSIONS:

Once the floor is properly leveled, the ground will be marked with the lines where the inside face of the panels of the swimming pool will be supported.

It is time to check the measurements.

If not, the exercise needs to be performed again.

SK INTERIOR DIMENSIONS:

Once the floor is properly leveled, the ground will be marked with the lines where the inside face of the panels of the swimming pool will be supported.

It is time to check the measurements.

If not, the exercise needs to be performed again.

RO DIMENSIUNI INTERIOARE:

După ce solul este nivelat corespunzător, se va marca terenul cu liniile pe care se vor sprijini fețele interioare ale panourilor piscinei.

Este timpul să verificăm măsurătorile.

În caz contrar, exercițiul trebuie să fie efectuat din nou.

SV INRE DIMENSIONER:

När golvet är ordentligt planat markeras marken med de linjer där insidan av poolens paneler stöds.

Det är dags att kontrollera mätningarna.

Om inte, måste övningen utföras igen.

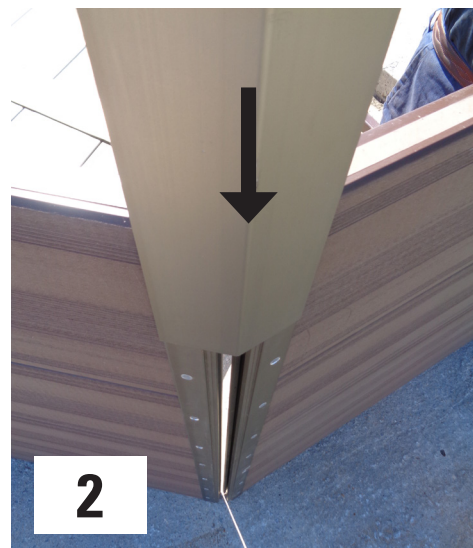

EN PLACEMENT OF THE PANELS Your pool must be centred on the concrete base.

-All your pool's panels are identical except the one that carries filtration. Place it in the center of one of the two longer areas of your swimming pool. (photo 1) (KPCOR60)

-The inside face of the panels (smooth surface) must be above the polygon just marked in the previous paragraph.

-Use the vertical profiles to join the panels together (photo 2). It is recommended that the plastic protecting the profile on the inside be removed before mounting the panels. -It's very important to move the panels with great caution and between two people. The marks or scratches caused to the panels due to poor handling are not covered by the warranty. If you have problems inserting the profile, move the panels until they have the same angle and distance as the profile. The profile will thus enter more easily.

Note: if your pool includes a led projector (KPCOR60L) check page 55. it is important to thoroughly read the instruction manual of the spotlight before installing the liner.

PL ROZMIESZCZENIE PANELI Wyśrodkuj basen na płycie betonowej.

-Wszystkie panele basenu są identyczne, z wyjątkiem tego, w którym montujemy filtr. Należy umieścić go na środku jednego z dwóch dłuższych miejsc w basenie. (Zdjęcie nr 1) (KPCOR60)

-Wewnętrzna strona paneli (gładka powierzchnia) musi zostać umiejscowiona powyżej wieloboków, tak jak zostało to zaznaczone w poprzednim akapicie.

-Użyj pionowych profili do połączenia ze sobą paneli (zdjęcie nr 2). Przed montażem paneli należy usunąć folię chroniącą profil od strony wewnętrznej. -Należy zachować szczególną ostrożność podczas przenoszenia paneli i czynność ta musi być wykonywana przez 2 osoby. Ślady lub zadrapania powstałe na panelach w wyniku niewłaściwego przenoszenia nie są objęte gwarancją. W przypadku problemów z montażem profilu należy przesunąć panele tak, aby zachować taki sam kąt i odległość jak profil. Dzięki temu profil będzie wchodził łatwiej.

Uwaga: Jeśli basen jest wyposażony w projektor LED (KPCOR60L), sprawdź stronę 55. Przed zainstalowaniem linera należy dokładnie zapoznać się z instrukcją obsługi projektora.

CS PLACEMENT OF THE PANELS Your pool must be centred on the concrete base.

-All your pool's panels are identical except the one that carries filtration. Place it in the center of one of the two longer areas of your swimming pool. (photo 1) (KPCOR60)

-The inside face of the panels (smooth surface) must be above the polygon just marked in the previous paragraph.

-Use the vertical profiles to join the panels together (photo 2). It is recommended that the plastic protecting the profile on the inside be removed before mounting the panels. -It's very important to move the panels with great caution and between two people. The marks or scratches caused to the panels due to poor handling are not covered by the warranty. If you have problems inserting the profile, move the panels until they have the same angle and distance as the profile. The profile will thus enter more easily.

Note: if your pool includes a led projector (KPCOR60L) check page 55. it is important to thoroughly read the instruction manual of the spotlight before installing the liner.

SK PLACEMENT OF THE PANELS Your pool must be centred on the concrete base.

-All your pool's panels are identical except the one that carries filtration. Place it in the center of one of the two longer areas of your swimming pool. (photo 1) (KPCOR60)

-The inside face of the panels (smooth surface) must be above the polygon just marked in the previous paragraph.

-Use the vertical profiles to join the panels together (photo 2). It is recommended that the plastic protecting the profile on the inside be removed before mounting the panels. -It's very important to move the panels with great caution and between two people. The marks or scratches caused to the panels due to poor handling are not covered by the warranty. If you have problems inserting the profile, move the panels until they have the same angle and distance as the profile. The profile will thus enter more easily.

Note: if your pool includes a led projector (KPCOR60L) check page 55. it is important to thoroughly read the instruction manual of the spotlight before installing the liner.

RO AMPLASAREA PANOURILOR Piscina trebuie să fie centrată pe baza de beton.

-Toate panourile piscinei sunt identice, cu excepția aceleia prin care se asigură filtrarea. Așezați-l în centrul uneia dintre cele două zone mai lungi ale piscinei. (foto 1) (KPCOR60)

-Fața interioară a panourilor (suprafața netedă) trebuie să se afle deasupra poligonului marcat în paragraful anterior.

-Utilizați profilurile verticale pentru a îmbina panourile între ele (foto 2). Se recomandă ca plasticul care protejează interiorul profilului să fie îndepărtat înainte de montarea panourilor. -Este foarte important să mutați panourile cu mare atenție și de către două persoane. Semnele sau zgărieturile provocate pe panouri din cauza unei manipulări necorespunzătoare nu sunt acoperite de garanție. Dacă întâmpinați probleme la inserarea profilului, mutați panourile până când acestea au același unghi și aceeași distanță ca și profilul. Astfel, profilul va intra mai ușor.

Notă: dacă piscina include un proiector cu leduri (KPCOR60L) vedeți pagina 55. Este important să citiți cu atenție manualul de instrucțiuni al proiecteurului înainte de a monta linerul.

SV LACERING AV PANELARNA Din pool måste vara centrerad på betongbotten.

-Alla poolens paneler är identiska utom den som bär filtrering. Placera den i mitten av en av de två längre områdena i din pool. (foto 1) (KPCOR60)

-Panelernas insida (slät yta) måste vara ovanför polygonen som just markerats i föregående avsnitt.

-Använd de vertikala profilerna för att sammanfoga panelerna (foto 2). Det rekommenderas att plasten som skyddar profilen på insidan tas bort innan du monterar panelerna. -Det är mycket viktigt att flytta panelerna med stor försiktighet och mellan två personer. Märken eller repor som orsakats av panelerna på grund av dålig hantering täcks inte av garantin. Om du har problem med att infoga profilen, flytta panelerna tills de har samma vinkel och avstånd som profilen. Profilen kommer alltså lättare in.

Obs: om din pool innehåller en ledd projektor (KPCOR60L), se sidan 55. Det är viktigt att du läser igenom instruktionsboken för strålkastaren innan du installerar liner.



EN

LAYOUT OF THE WEDGES:

Now is the time to remove the outer protection of the vertical aluminum profiles

Revise the internal measurements of your pool. Take the metallic wedges and place them as in photo 1. The parts must be centred on the vertical profiles (photo 3).

Tighten the columns well around the entire layer of boards. •Vertically drill the layer using a drill with a \varnothing 10mm bit for concrete, and using the column as a guide (photo 4). The depth of the hole should be at least 100mm to guarantee good fixing. •Place the fixing bolts (with washers and nuts) into the holes and fix them with the help of a hammer (photo 5). **COMPLETELY hammer in the fixing bolts (only the head should be visible).** •Tighten crosswise the 4 nuts (photo 6).

PL

ROZMIESZCZENIE WSPORNIKÓW:

W tym momencie należy usunąć zewnętrzną ochronę pionowych profili aluminiowych.

Sprawdź wewnętrzne wymiary basenu. Zamontuj metalowe wsporniki jak na zdjęciu nr 1. Elementy muszą zostać wyśrodkowane na pionowych profilach (zdjęcie nr 3).

Dobrze dokręć kolumny wokół całej warstwy płyt. •Nawierć pionowo warstwę za pomocą wiertła o średnicy \varnothing 10 mm do betonu, używając kolumny jako prowadnicy (zdjęcie nr 4). Głębokość otworu powinna wynosić co najmniej 100 mm, aby zagwarantować odpowiednie zamocowanie. •Włóż śruby mocujące (z uszczelkami i nakrętkami) do otworów i zamocuj je za pomocą młotka (zdjęcie nr 5). **Wbij śruby mocujące CAŁKOWICIE (powinien być widoczny tylko łeb).** •Dokręć na krzyż 4 nakrętki (zdjęcie nr 6).

CS

LAYOUT OF THE WEDGES:

Now is the time to remove the outer protection of the vertical aluminum profiles

Revise the internal measurements of your pool. Take the metallic wedges and place them as in photo 1. The parts must be centred on the vertical profiles (photo 3).

Tighten the columns well around the entire layer of boards. •Vertically drill the layer using a drill with a \varnothing 10mm bit for concrete, and using the column as a guide (photo 4). The depth of the hole should be at least 100mm to guarantee good fixing. •Place the fixing bolts (with washers and nuts) into the holes and fix them with the help of a hammer (photo 5). **COMPLETELY hammer in the fixing bolts (only the head should be visible).** •Tighten crosswise the 4 nuts (photo 6).

SK

LAYOUT OF THE WEDGES:

Now is the time to remove the outer protection of the vertical aluminum profiles

Revise the internal measurements of your pool. Take the metallic wedges and place them as in photo 1. The parts must be centred on the vertical profiles (photo 3).

Tighten the columns well around the entire layer of boards. •Vertically drill the layer using a drill with a \varnothing 10mm bit for concrete, and using the column as a guide (photo 4). The depth of the hole should be at least 100mm to guarantee good fixing. •Place the fixing bolts (with washers and nuts) into the holes and fix them with the help of a hammer (photo 5). **COMPLETELY hammer in the fixing bolts (only the head should be visible).** •Tighten crosswise the 4 nuts (photo 6).

RO

DISPUNEREA PENELOR:

Acum este momentul pentru a elimina protecția exterioară a profilurilor verticale din aluminiu

Verificați măsurătorile interne ale piscinei. Luați penele metalice și așezați-le ca în fotografia 1. Piesele trebuie să fie centrate pe profilurile verticale (foto 3).

Strângeți bine coloanele în jurul întregului strat de plăci. •Perforați vertical stratul folosind o bormașină cu un burghiu de \varnothing 10 mm pentru beton și folosind coloana ca element de ghidare (foto 4). Adâncimea găurii trebuie să fie de cel puțin 100 mm pentru a garanta o fixare bună. •Puneți bolțurile de fixare (cu șuruburi și piulițe) în găuri și fixați-le cu ajutorul unui ciocan (foto 5). **Introduceți complet șuruburile de fixare cu ciocanul (trebuie să rămână vizibil doar capul).** •Strângeți în cruce cele 4 piulițe (foto 6).

SV

UTLÄGGNING AV KILAR:

Nu är det dags att ta bort det yttre skyddet av de vertikala aluminiumprofilerna

Revidera de interna mätningarna i din pool. Ta metallkilarna och placera dem som på bild 1. Delarna måste vara centrerade på de vertikala profilerna (foto 3). Dra åt kolumnerna väl runt hela skivskiktet. •Borra lagret vertikalt med en borrar med en \varnothing 10 mm bit för betong och använd kolonnen som vägledning (foto 4). Hålets djup bör vara minst 100 mm för att garantera en god fästning. •Placera fästbultarna (med brickor och muttrar) i hålen och fäst dem med hjälp av en hummer (foto 5).

HAMRA helt i fästbultarna (endast huvudet ska vara synligt)• Dra åt de fyra muttrarna tvärs (foto 6).



Look for us in our YouTube channel to help you with the assembly.

You Tube



- EN** - It is normal that there is space left between the panels and the columns (photo 7). When you fill the pool of water, the panels will touch the columns due to the force of the water.
- PL** - Normalne jest, że pomiędzy panelami i kolumnami pozostaje wolna przestrzeń (zdjęcie nr 7). Po napełnieniu basenu wodą, panele będą dotykać kolumn pod wpływem jej nacisku.
- CS** - It is normal that there is space left between the panels and the columns (photo 7). When you fill the pool of water, the panels will touch the columns due to the force of the water.
- SK** - It is normal that there is space left between the panels and the columns (photo 7). When you fill the pool of water, the panels will touch the columns due to the force of the water.
- RO** - Este normal să rămână spațiu între panouri și coloane (foto 7). Atunci când umpleți piscina cu apă, panourile vor atinge coloanele datorită presiunii apei.
- SV** - Det är normalt att det finns utrymme kvar mellan panelerna och kolumnerna (foto 7). När du fyller poolen med vatten kommer panelerna att beröra kolumnerna på grund av vattnets kraft.



8



9

EN **PLACEMENT OF THE TOP COPPINGS**

Locate references A, B, C and D and place them in your pool as shown in figure 10. One part has a cut-out for the skimmer (photo 9). This must be placed in the filtering panel. It is fundamental that the pieces are levelled to avoid future problems when positioning the metal trimming. The main cause can be due to an incorrect levelling of the terrain. We suggest supporting the coping from outside of the pool at the joint of the vertical metal profile.

PL **MONTAŻ PANELI BRZEGOWYCH BASENU**

Znajdź elementy A, B, C i D i umieść je w basenie jak pokazano na rysunku nr 10. Jedna z części ma wycięcie na skimmer (zdjęcie nr 9). Należy umieścić ją w panelu z filtrem. Podstawową sprawą jest wypoziomowanie tych elementów, aby uniknąć problemów przy ustawianiu metalowych listew w przyszłości. Główną przyczyną może być niewłaściwe wypoziomowanie terenu. Należy podprzeć panel brzegowy od zewnątrz basenu na styku pionowego profilu metalowego.

CS **PLACEMENT OF THE TOP COPPINGS**

Locate references A, B, C and D and place them in your pool as shown in figure 10. One part has a cut-out for the skimmer (photo 9). This must be placed in the filtering panel. It is fundamental that the pieces are levelled to avoid future problems when positioning the metal trimming. The main cause can be due to an incorrect levelling of the terrain. We suggest supporting the coping from outside of the pool at the joint of the vertical metal profile.

SK **PLACEMENT OF THE TOP COPPINGS**

Locate references A, B, C and D and place them in your pool as shown in figure 10. One part has a cut-out for the skimmer (photo 9). This must be placed in the filtering panel. It is fundamental that the pieces are levelled to avoid future problems when positioning the metal trimming. The main cause can be due to an incorrect levelling of the terrain. We suggest supporting the coping from outside of the pool at the joint of the vertical metal profile.

RO **AMPLASAREA ORNAMENTELOR SUPERIOARE**

Localizați referințele A, B, C și D și plasați-le la piscină, astfel cum se prezintă în figura 10. Una dintre piese are un decupaj pentru skimmer (fotografia 9). Acesta trebuie să fie plasat în panoul de filtrare. Este esențial ca piesele să fie nivelate pentru a evita viitoare probleme la poziționarea garniturii metalice. Principala cauză poate fi cauzată de o nivelare incorectă a terenului. Vă sugerăm să sprijiniți ornamentul dinspre exteriorul piscinei la îmbinarea cu profilul metalic vertical.

SV **PLACERING AV DE ÖVERSTA KOPPLINGARNA**

Leta reda på referenser A, B, C och placera dem i din pool som visas i figur 10. En del har en utskärning för skimmern (foto 9). Detta måste placeras i filtreringspanelen. Det är grundläggande att bitarna är planade för att undvika framtida problem vid placering av metallskärningen. Den främsta orsaken kan bero på en felaktig utjämnning av terrängen. Vi föreslår att du stöder avskärningen från utsidan av poolen vid fogen av den vertikala metallprofilen.

EN IMPORTANT: Only in the case of contacting with the after-sales service due to an incident.
 1- Locate your pool in the following tables
 2- Search for exact piece needed Check the drawing.
 3- You must consider that each reference refers to a single piece, one unit.

PL WAŻNE: Tylko w przypadku kontaktu z obsługą posprzedażową w związku z zaistniałym zdarzeniem.
 1. Znajdź swój basen w poniższych tabelach.
 2. Znajdź identyczną potrzebną część. Sprawdź rysunek.
 3. Weź pod uwagę, aby każdy odnośnik oznacza jeden element, jedną część.

CS IMPORTANT: Only in the case of contacting with the after-sales service due to an incident.
 1- Locate your pool in the following tables
 2- Search for exact piece needed Check the drawing.
 3- You must consider that each reference refers to a single piece, one unit.

SK IMPORTANT: Only in the case of contacting with the after-sales service due to an incident.
 1- Locate your pool in the following tables
 2- Search for exact piece needed Check the drawing.
 3- You must consider that each reference refers to a single piece, one unit.

RO IMPORTANT: Numai în cazul contactării cu serviciul post-vânzare din cauza unui incident.
 1- Localizați piscina în tabelele următoare
 2- Căutați exact piesa necesară Verificați desenul.
 3- Trebuie să considerați că fiecare referință se referă la o singură piesă, o unitate.

SV VIKTIG: Endast vid kontakt med kundservice på grund av en incident.
 1- Hitta din pool i följande tabeller
 2- Sök efter exakt stycke som behövs Kontrollera ritningen.
 3- Du måste tänka på att varje referens hänvisar till ett enda stycke, en enhet.

A = PLYCOMP90

B = PLYCOMP9045

C = PLYCOMP9045SK

D = PLYCOMP45SK

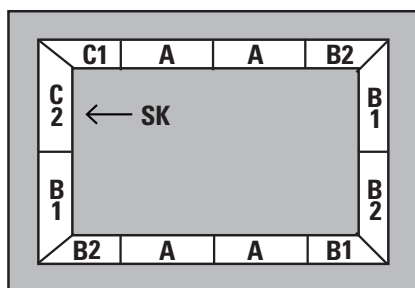

**KPCOR60
KPCOR60L**

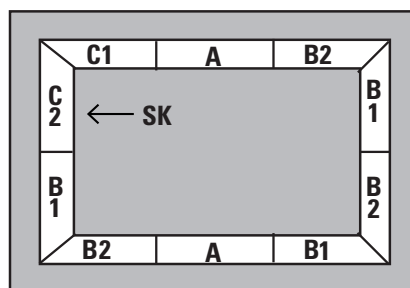

KPCOR46

10

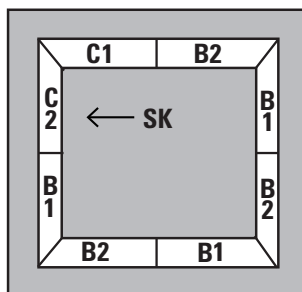

KPCOR28

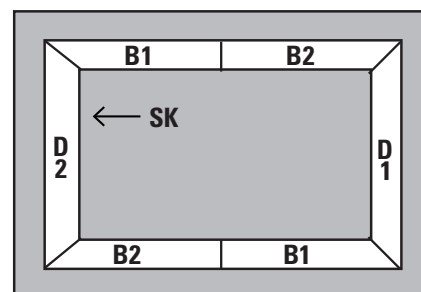

KPCOR2814

| KPCOR60(L) | | |
|----------------|--|---------|
| PLYCOMP9045P | | C1 = B1 |
| PLYCOMP4590P | | B2 |
| PLYCOMP9045SKP | | C2 |
| PLYCOMP90P | | A |

| KPCOR46 | | |
|----------------|--|---------|
| PLYCOMP9045P | | C1 = B1 |
| PLYCOMP4590P | | B2 |
| PLYCOMP9045SKP | | C2 |
| PLYCOMP90P | | A |

| KPCOR28 | | |
|----------------|--|---------|
| PLYCOMP9045P | | C1 = B1 |
| PLYCOMP4590P | | B2 |
| PLYCOMP9045SKP | | C2 |

| KPCOR2814 | | |
|--------------|--|----|
| PLYCOMP9045P | | B1 |
| PLYCOMP4590P | | B2 |
| PLYCOMP45P | | D1 |
| PLYCOMP45SKP | | D2 |



11

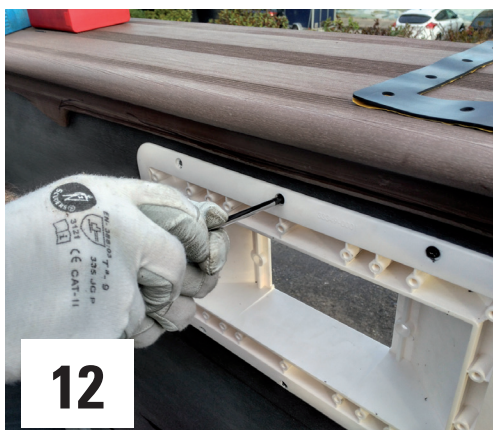

12



13

EN PLACEMENT OF THE SKIMMER

- Completely assemble the skimmer and screw it from the inside of the pool.
- If you find it difficult to screw it to the wall, you can use a 2 mm drill bit and make a guide for the screw. This will make the work easier.
- With the glue, place the seal facing inward. This is very important in order to set the plastic sleeve properly and prevent water leakage. Photo 13.

PL MONTAŻ SKIMMERA

- Zmontuj cały skimmer i przykręć go od wewnątrz basenu.
- Jeśli masz trudności z przykręceniem go do ściany, możesz wykonać otwór dla śruby za pomocą wiertła 2 mm. Ułatwi to pracę.
- Zamontuj uszczelkę (strona z warstwą kleju musi być skierowana do środka). Jest to bardzo ważne, aby prawidłowo założyć plastikowy liner i zapobiec przeciekaniu wody. Zdjęcie nr 13.

CS PLACEMENT OF THE SKIMMER

- Completely assemble the skimmer and screw it from the inside of the pool.
- If you find it difficult to screw it to the wall, you can use a 2 mm drill bit and make a guide for the screw. This will make the work easier.
- With the glue, place the seal facing inward. This is very important in order to set the plastic sleeve properly and prevent water leakage. Photo 13.

SK PLACEMENT OF THE SKIMMER

- Completely assemble the skimmer and screw it from the inside of the pool.
- If you find it difficult to screw it to the wall, you can use a 2 mm drill bit and make a guide for the screw. This will make the work easier.
- With the glue, place the seal facing inward. This is very important in order to set the plastic sleeve properly and prevent water leakage. Photo 13.

RO AȘEZAREA SKIMMERULUI

- Asamblați complet skimmerul și înșurubați-l din interiorul piscinei.
- Dacă vă este greu să-l înșurubați de perete, puteți utiliza un burghiu de 2 mm și puteți face un ghidaj pentru șurub. Acest lucru va ușura munca.
- Cu lipici, așezați sigiliul orientat spre interior. Acest lucru este foarte important pentru a seta corect manșonul din plastic și pentru a preveni scurgerile de apă. Foto 13.

SV PLACERING AV SKIMMER

- Montera helt av skimmern och skruva in den från insidan av poolen.
- Om du har svårt att skruva fast den på väggen kan du använda en 2 mm borrkrona och göra en guide för skruven. Detta underlättar arbetet.
- Placera tätningen med limmet inåt. Detta är mycket viktigt för att kunna ställa in plasthylsan ordentligt och förhindra vattenläckage. Foto 13.



EN

PROTECTIVE GROUND BLANKET

- It is recommended the duck tape be used to cover the rivets of the vertical profiles, which will be in contact with the swimming pool liner. This prevents the liner from being pricked. (Photo 14).

- Before covering the ground, it is advisable to sweep and vacuum the concrete floor to remove dirt, such as pebbles, branches, leaves, etc.
- Place the cover to protect the sleeve. Remove any remaining wrinkles so that they do not appear once the pool fills with water.
- Cut the cover according to your swimming pool model, adapting it to the shape of your swimming pool.

PL

KOC OCHRONNY DO PODŁOŻA

- Zaleca się oklejenie taśmą kaczka nitów profili pionowych będących w kontakcie z linerem basenu. Zapobiega to przebiciu wkładu. (Zdjęcie nr 14).

- Przed przystąpieniem do przykrycia podłoża zaleca się zamieść i odkurzyć posadzkę betonową w celu usunięcia zanieczyszczeń, takich jak: kamyczki, gałęzie, liście itp.
- Załóż koc w celu ochrony wkładu basenowego. Usuń wszelkie pomarszczenia, aby nie pojawiły się po napełnieniu basenu wodą.
- Przytnij koc zgodnie z modelem basenu, dostosowując go do jego kształtu.

CS

PROTECTIVE GROUND BLANKET

- It is recommended the duck tape be used to cover the rivets of the vertical profiles, which will be in contact with the swimming pool liner. This prevents the liner from being pricked. (Photo 14).

- Before covering the ground, it is advisable to sweep and vacuum the concrete floor to remove dirt, such as pebbles, branches, leaves, etc.
- Place the cover to protect the sleeve. Remove any remaining wrinkles so that they do not appear once the pool fills with water.
- Cut the cover according to your swimming pool model, adapting it to the shape of your swimming pool.

SK

PROTECTIVE GROUND BLANKET

- It is recommended the duck tape be used to cover the rivets of the vertical profiles, which will be in contact with the swimming pool liner. This prevents the liner from being pricked. (Photo 14).

- Before covering the ground, it is advisable to sweep and vacuum the concrete floor to remove dirt, such as pebbles, branches, leaves, etc.
- Place the cover to protect the sleeve. Remove any remaining wrinkles so that they do not appear once the pool fills with water.
- Cut the cover according to your swimming pool model, adapting it to the shape of your swimming pool.

RO

PĂTURĂ DE PROTECȚIE PENTRU SOL

- Se recomandă utilizarea păturii de protecție pentru a acoperi niturile profilelor verticale, care vor fi în contact cu căptușeala piscinei. Acest lucru împiedică înțeparea căptușelii. (Foto 14).

- Înainte de a acoperi solul, este recomandabil să măturați și să aspirați podeaua din beton pentru a îndepărta murdăria, cum ar fi pietricele, ramuri, frunze etc.
- Așezați capacul pentru a proteja manșonul. Îndepărtați orice riduri rămase, astfel încât să nu apară odată ce piscina se umple cu apă.
- Tăiați capacul în funcție de modelul dvs. de piscină, adaptându-l la forma piscinei dvs.

SV

SKYDDSJORDFILT

- Det rekommenderas att anka tejpen används för att täcka nitarna på de vertikala profilerna, som kommer i kontakt med poollinern. Detta förhindrar att linern prickas. (Foto 14).

- Innan du täcker marken är det lämpligt att sopa och dammsuga betonggolvet för att avlägsna smuts, som småsten, grenar, löv etc.
- Placera locket för att skydda hylsan. Ta bort eventuella resterande rynkor så att de inte syns när poolen fylls med vatten.
- Klipp av locket enligt din simbassängmodell och anpassa det till formen på din pool.



EN

PLACEMENT OF THE SLEEVE (LINER) - If your pool includes the LED light, check the assembly manual before installing the liner.

- Remove the sleeve from the box with great care. Stretch and extend it in the shade so that it recovers its shape. Perform this step at least two hours before its placement. The ideal temperature for mounting the sleeve is 25 - 30°C.

- Do not use sharp objects they could prick the sleeve. The warranty does not cover punctures due to poor handling. Take off your shoes.

- Extend the cover, pulling it to the corners of the swimming pool. It is very important to take this step seriously, since the final aesthetic of your pool will depend on proper placement of the sleeve.

- Insert the sleeve in the attachment slot. If at some point during completion of this operation an excess of sheath is observed on the wall, spread the excess out evenly around the perimeter of the pool. This will prevent wrinkles.

- Once in place, fill the pool with 2 - 3 cm of water and extend the sleeve wrinkles well. If folds remain in the bottom is not a reason to replace the sleeve with another, as it is not a manufacturing defect. Take your time.

- Very Important: (*) Locate the serial number on the upper part of the wall of the sleeve, near the weld that joins the side.

Write it down in the instruction sheet box for potential claims.

PL

MONTAŻ WKŁADU BASENOWEGO (LINERA) - Jeśli Twój basen wyposażony jest w oświetlenie LED, sprawdź instrukcję montażu przed zainstalowaniem linera.

- Wyjmij wkład basenowy z opakowania z zachowaniem szczególnej ostrożności. Rozwiń go całkowicie w cieniu, aby odzyskał swój kształt. Wykonaj tę czynność co najmniej dwie godziny przed jego montażem w basenie. Idealna temperatura do montażu wkładu basenowego to 25 - 30 °C.

- Nie używaj ostrych narzędzi, które mogą przebić wkład. Gwarancja nie obejmuje szkód spowodowanych przebicciem w wyniku niewłaściwej obsługi. Zdejmij buty.

- Rozłóż liner, rozciągając go do rogów basenu. Bardzo ważne jest poważne potraktowanie tego kroku, gdyż od prawidłowego ułożenia wkładu będzie zależał ostateczny wygląd basenu.

- Włóż wkład w szczelinę mocującą. Jeśli podczas wykonywania tej czynności na ścianie pojawi się nadmiar linera, należy równomiernie go rozłożyć na obwodzie basenu. Zapobiegnie marszczeniu się wkładu.

- Po założeniu, napełnij basen wodą na 2-3 cm i dobrze rozciągnij pomarszczony liner. Jeśli fałdy znajdują się na dnie, nie jest to powodem do wymiany wkładu na inny, ponieważ nie jest to wada fabryczna. Nie spiesz się.

- Bardzo ważne: (*) Znajdź numer seryjny znajdujący się w górnej części ściany wkładu, w miejscu połączenia boków.

Zapisz go na pudełku z instrukcją obsługi na wypadek ewentualnych reklamacji.

CS

PLACEMENT OF THE SLEEVE (LINER) - If your pool includes the LED light, check the assembly manual before installing the liner.

- Remove the sleeve from the box with great care. Stretch and extend it in the shade so that it recovers its shape. Perform this step at least two hours before its placement. The ideal temperature for mounting the sleeve is 25 - 30°C.

- Do not use sharp objects they could prick the sleeve. The warranty does not cover punctures due to poor handling. Take off your shoes.

- Extend the cover, pulling it to the corners of the swimming pool. It is very important to take this step seriously, since the final aesthetic of your pool will depend on proper placement of the sleeve.

- Insert the sleeve in the attachment slot. If at some point during completion of this operation an excess of sheath is observed on the wall, spread the excess out evenly around the perimeter of the pool. This will prevent wrinkles.

- Once in place, fill the pool with 2 - 3 cm of water and extend the sleeve wrinkles well. If folds remain in the bottom is not a reason to replace the sleeve with another, as it is not a manufacturing defect. Take your time.

- Very Important: (*) Locate the serial number on the upper part of the wall of the sleeve, near the weld that joins the side.

Write it down in the instruction sheet box for potential claims.

SK

PLACEMENT OF THE SLEEVE (LINER) - If your pool includes the LED light, check the assembly manual before installing the liner.

- Remove the sleeve from the box with great care. Stretch and extend it in the shade so that it recovers its shape. Perform this step at least two hours before its placement. The ideal temperature for mounting the sleeve is 25 - 30°C.

- Do not use sharp objects they could prick the sleeve. The warranty does not cover punctures due to poor handling. Take off your shoes.

- Extend the cover, pulling it to the corners of the swimming pool. It is very important to take this step seriously, since the final aesthetic of your pool will depend on proper placement of the sleeve.

- Insert the sleeve in the attachment slot. If at some point during completion of this operation an excess of sheath is observed on the wall, spread the excess out evenly around the perimeter of the pool. This will prevent wrinkles.

- Once in place, fill the pool with 2 - 3 cm of water and extend the sleeve wrinkles well. If folds remain in the bottom is not a reason to replace the sleeve with another, as it is not a manufacturing defect. Take your time.

- Very Important: (*) Locate the serial number on the upper part of the wall of the sleeve, near the weld that joins the side.

Write it down in the instruction sheet box for potential claims.

RO

AȘEZAREA MÂNECII (LINER) - Dacă piscina dvs. include lumină LED, verificați manualul de asamblare înainte de a instala căptușeala.

- Scoateți manșonul din cutie cu mare grijă. Întindeți-l și extindeți-l la umbră, astfel încât să-și recapete forma. Efectuați acest pas cu cel puțin două ore înainte de plasarea acestuia. Temperatura ideală pentru montarea manșonului este de 25 - 30 °C.

- Nu folosiți obiecte ascuțite, deoarece ar putea înțepa măneca. Garanția nu acoperă punctiile din cauza manipulării slabe. Descalță-te.

- Extindeți capacul, trăgându-l în colțurile piscinei. Este foarte important să luați acest pas în serios, deoarece estetica finală a piscinei dvs. va depinde de amplasarea corectă a mănecii.

- Introduceți manșonul în fanta de fixare. Dacă la un moment dat în timpul finalizării acestei operații se observă un exces de teacă pe perete, răspândiți excesul uniform în jurul perimetrului bazinului. Acest lucru va preveni ridurile.

- O dată pe loc, umpleți piscina cu 2 - 3 cm de apă și extindeți bine ridurile mănecii. Dacă pliurile rămân în partea de jos nu este un motiv pentru a înlocui manșonul cu altul, deoarece nu este un defect de fabricație. Nu vă grăbiți.

- Foarte important: (*) Localizați numărul de serie pe partea superioară a peretelui manșonului, în apropierea sudurii care se unește lateral.

Scrieți-l în caseta cu foaia de instrucțiuni pentru eventualele daune.

SV

SLEEVE (LINER) PLACERING - Om din pool innehåller LED-lampan, kontrollera monteringsanvisningen innan du installerar linern.

- Ta bort hylsan ur lådan med stor försiktighet. Sträck ut och sträck ut den i skuggan så att den återfår sin form. Utför detta steg minst två timmar innan det placeras. Den perfekta temperaturen för montering av hylsan är 20 - 25 °C.

- Använd inte vassa föremål, de kan sticka hylsan. Garantin täcker inte punkteringar på grund av dålig hantering. Ta av dina skor.

- Dra ut locket och dra det till poolens hörn. Det är mycket viktigt att ta detta steg på allvar, eftersom den slutliga estetiken i din pool beror på korrekt placering av hylsan.

- För in hylsan i fästet. Om det vid något tillfälle under genomförandet av denna operation observeras ett överskott av mantel på väggen, ska du sprida överskottet jämnt runt poolens omkrets. Detta förhindrar rynkor.

Fyll poolen med 2-3 cm vatten när du väl är på plats och förläng rynkorna väl. Om vikningar förblir i botten är det inte en anledning att byta ut hylsan mot en annan, eftersom det inte är tillverkningsfel. Ta din tid.

- Väldigt viktigt: (*) Leta upp serienumret på den övre delen av hylsans vägg, nära svetsen som förenar sidan. Skriv ner det i instruktionsbladet för potentiella anspråk.

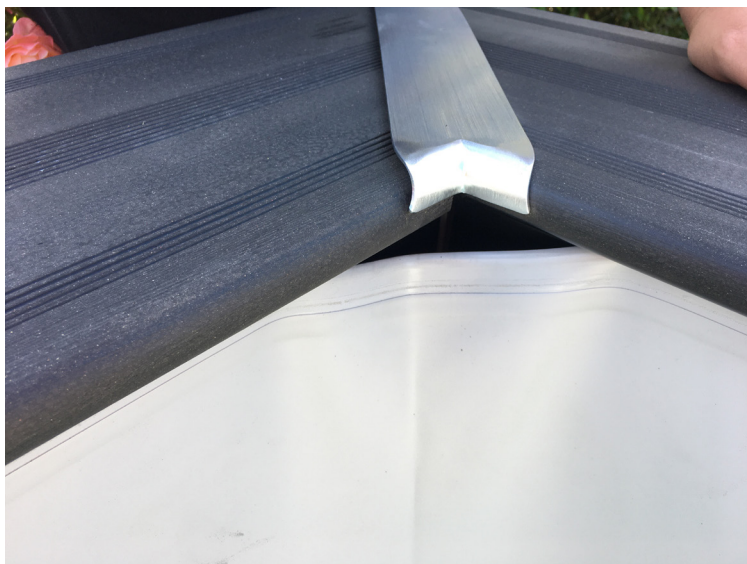

- EN** - Maybe the liner does not perfectly adjust to the corners of your pool. This is not a structural problem, simply aesthetic. Do not be surprised.
- When you start to fill the pool, remember to fill only up to 2-3 cm and remove all the wrinkles on the bottom from the interior, without any footwear. Also, you must adjust the corners at the bottom and sides of your pool. It is important that the liner is well distributed around the pool sides and perfectly fitted.
- If this problem occurs, try assembling it on a very sunny day with high temperature.
- In order for the liner to fit better in the corners of your pool, it is advisable to heat the liner, e.g. with a hairdryer at short intervals of time.
- PL** - Być może liner nie dopasowuje się idealnie do narożników Twojego basenu. Nie jest to problem strukturalny, tylko estetyczny. Nie martw się.
- Kiedy zaczniesz napełniać basen, pamiętaj, aby napełnić go tylko do 2-3 cm i usunąć wszystkie pomarszczenia na dnie od wewnątrz, bez obuwia. Ponadto należy dopasować rogi na dnie i po bokach basenu. Ważne jest, aby liner był dobrze rozłożony po bokach basenu i idealnie dopasowany.
- Jeśli wystąpi ten problem, spróbuj zamontować go w bardzo słoneczny dzień, przy wysokiej temperaturze.
- W celu lepszego dopasowania lineru do rogów basenu, zaleca się podgrzanie go, np. suszarką do włosów w krótkich odstępach czasu.
- CS** - Maybe the liner does not perfectly adjust to the corners of your pool. This is not a structural problem, simply aesthetic. Do not be surprised.
- When you start to fill the pool, remember to fill only up to 2-3 cm and remove all the wrinkles on the bottom from the interior, without any footwear. Also, you must adjust the corners at the bottom and sides of your pool. It is important that the liner is well distributed around the pool sides and perfectly fitted.
- If this problem occurs, try assembling it on a very sunny day with high temperature.
- In order for the liner to fit better in the corners of your pool, it is advisable to heat the liner, e.g. with a hairdryer at short intervals of time.
- SK** - Maybe the liner does not perfectly adjust to the corners of your pool. This is not a structural problem, simply aesthetic. Do not be surprised.
- When you start to fill the pool, remember to fill only up to 2-3 cm and remove all the wrinkles on the bottom from the interior, without any footwear. Also, you must adjust the corners at the bottom and sides of your pool. It is important that the liner is well distributed around the pool sides and perfectly fitted.
- If this problem occurs, try assembling it on a very sunny day with high temperature.
- In order for the liner to fit better in the corners of your pool, it is advisable to heat the liner, e.g. with a hairdryer at short intervals of time.
- RO** - Poate că linia nu se ajustează perfect la colțurile piscinei. Aceasta nu este o problemă structurală, pur și simplu estetică. Nu fi surprins.
- Când începeți să prăguiți piscina, nu uitați să umpleți doar până la 2-3 cm și să îndepărtați toate ridurile de pe fund din interior, fără încălțăminte. De asemenea, trebuie să reglați colțurile din partea inferioară și laterală a piscinei. Este important ca căptușeala să fie bine distribuită în jurul laturilor piscinei și perfect montată.
- Dacă apare această problemă, montați-o în tavă într-o zi foarte însorită, cu temperatură ridicată.
- Pentru ca linia să se potrivească mai bine în colțurile piscinei, este recomandabil să încălziți linia, de exemplu, cu un uscător de păr la intervale scurte de timp.
- SV** - Kanske passar inte linern perfekt till poolens hörn. Detta är inte ett strukturellt problem, bara estetiskt. Bli inte överraskad.
- När du börjar sälla poolen, kom ihåg att bara fylla upp till 2-3 cm och ta bort alla rynkor på botten från inredningen, utan några skor. Du måste också justera hörnen längst ner och på sidorna av din pool. Det är viktigt att linern är väl fördelat runt poolens sidor och perfekt monterat.
- Om detta problem uppstår, montera brickan på en mycket solig dag med hög temperatur.
- För att linern ska passa bättre i poolens hörn är det lämpligt att värma linern, t.ex. med en hårtork, med korta intervaller.

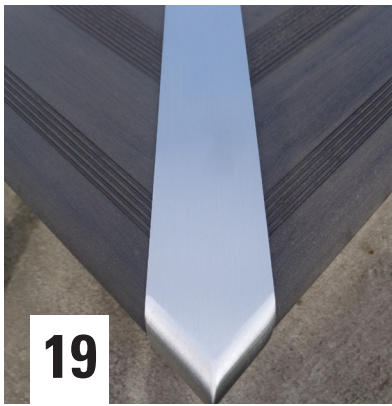

19

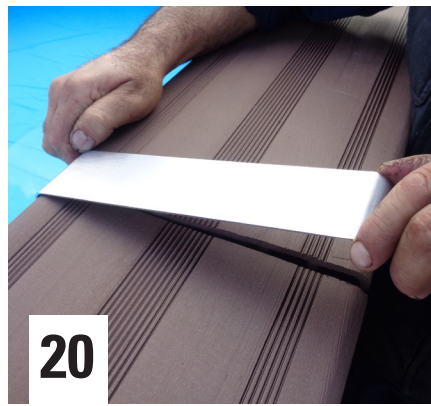

20

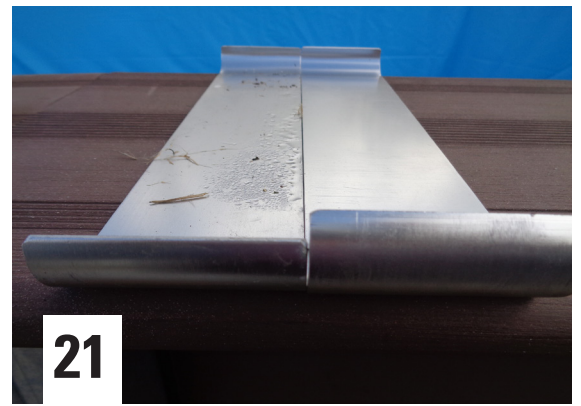

21

EN **INSTALLATION OF THE TOP RAILS' TRIMS**

This piece covers the joints of the coping (there must be a space between the coping). It is aesthetic.

Possible due to irregularities of the terrain the trim does not fit completely. If this happens, do not worry because it does not affect the structural system. In that case we suggest using double faced tape or Velcro.

- Look for the trims. All pools have trims with an angular shape. Place them in the coping's connections (photo 19)
- Straight area: The ends are different. Place the longest part on the inside of the pool. (photos 20 and 21).
- Screws are not necessary.

PL **MONTAŻ LISTEW WYKOŃCZENIOWYCH GÓRNYCH BRZEGÓW**

Element ten zakrywa połączenia paneli brzegowych (pomiędzy panelami musi być przestrzeń). Jest to element estetyczny.

Możliwe, że z powodu nierówności terenu, listwa nie zostanie całkowicie dopasowana. Jeśli tak się stanie, nie należy się martwić, ponieważ nie ma to wpływu na strukturę basenu. W takim przypadku sugerujemy użycie taśmy dwustronnej lub rzepu.

- Zwróć uwagę na wykończenia. Wszystkie baseny mają listwy wykończeniowe o kanciastym kształcie. Umieść je w miejscu połączenia paneli (zdjęcie nr 19).
- Prosta powierzchnia: Końce są różne. Najdłuższą część umieszczamy po wewnętrznej stronie basenu. (Zdjęcie nr 20 i 21).
- Śruby nie są konieczne

CS **INSTALLATION OF THE TOP RAILS' TRIMS**

This piece covers the joints of the coping (there must be a space between the coping). It is aesthetic.

Possible due to irregularities of the terrain the trim does not fit completely. If this happens, do not worry because it does not affect the structural system. In that case we suggest using double faced tape or Velcro.

- Look for the trims. All pools have trims with an angular shape. Place them in the coping's connections (photo 19)
- Straight area: The ends are different. Place the longest part on the inside of the pool. (photos 20 and 21).
- Screws are not necessary.

SK **INSTALLATION OF THE TOP RAILS' TRIMS**

This piece covers the joints of the coping (there must be a space between the coping). It is aesthetic.

Possible due to irregularities of the terrain the trim does not fit completely. If this happens, do not worry because it does not affect the structural system. In that case we suggest using double faced tape or Velcro.

- Look for the trims. All pools have trims with an angular shape. Place them in the coping's connections (photo 19)
- Straight area: The ends are different. Place the longest part on the inside of the pool. (photos 20 and 21).
- Screws are not necessary.

RO **MONTAREA FINISAJELOR ȘINELOR SUPERIOARE**

Această piesă acoperă îmbinările ornamentului (trebuie să existe un spațiu între ornamente). Este estetic.

Este posibil ca, din cauza neregularităților terenului, finisajul să nu se potrivească complet. Dacă se întâmplă acest lucru, nu vă faceți griji, deoarece nu afectează sistemul structural. În acest caz, vă sugerăm să folosiți bandă adezivă cu față dublă sau Velcro.

- Căutați finisajele. Toate piscinele au finisaje cu o formă unghiulară. Așezați-le în racordurile ornamentului (foto 19)
- Zona dreaptă: Capetele sunt diferite. Așezați partea cea mai lungă în interiorul bazinului. (fotografiile 20 și 21).
- Nu sunt necesare șuruburi.

SV **INSTALLATION AV DE ÖVERSTA SPÅREN**

Detta stycke täcker fogarna på tätningen (det måste finnas ett mellanrum mellan tätningen). Det är estetiskt.

Möjligt på grund av ojämnheter i terrängen passar inte trimmen helt. Om detta händer, oroa dig inte eftersom det inte påverkar det strukturella systemet. I så fall föreslår vi att du använder dubbelband eller kardborreband.

- Leta efter trimmarna. Alla pooler har kantar med en vinkelform. Placera dem i kopplingsanslutningarna (foto 19)
- Rakt område: Ändarna är olika. Placera den längsta delen på insidan av poolen. (foto 20 och 21).
- Skruvar är inte nödvändiga.



22

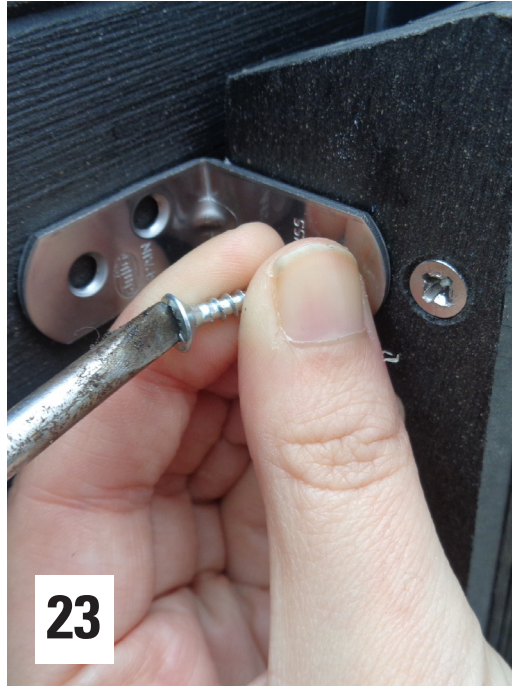

23



24

EN INSTALLATION OF THE STRUCTURAL SYSTEM TRIM

This is to cover the vertical posts (photo 22) to give the swimming pool a nicer aesthetic. This piece is for decoration only. Look for some brackets and screws (4 x 16 mm) that you will find in the bag KITENV. Screw the bracket as you prefer. In photo 23 there is an example. Two screws for each bracket is enough.

PL MONTAŻ WYKOŃCZENIA STRUKTURY BASENU

Służy do zakrycia pionowych kolumn (zdjęcie nr 22), aby nadać basenowi lepszą estetykę. Ten element służy wyłącznie do dekoracji. W torbie KITENV znajdują się zawiasy i śruby (4 x 16 mm). Przykręć wspornik według własnego uznania. Na zdjęciu nr 23 znajduje się przykład. Wystarczy użyć dwie śruby z każdym zawiasem.

CS INSTALLATION OF THE STRUCTURAL SYSTEM TRIM

This is to cover the vertical posts (photo 22) to give the swimming pool a nicer aesthetic. This piece is for decoration only. Look for some brackets and screws (4 x 16 mm) that you will find in the bag KITENV. Screw the bracket as you prefer. In photo 23 there is an example. Two screws for each bracket is enough.

SK INSTALLATION OF THE STRUCTURAL SYSTEM TRIM

This is to cover the vertical posts (photo 22) to give the swimming pool a nicer aesthetic. This piece is for decoration only. Look for some brackets and screws (4 x 16 mm) that you will find in the bag KITENV. Screw the bracket as you prefer. In photo 23 there is an example. Two screws for each bracket is enough.

RO INSTALAREA SISTEMULUI STRUCTURAL TRIM

Aceasta este pentru a acoperi stâlpii verticali (foto 18) pentru a oferi piscinei o estetică mai plăcută. Această piesă este doar pentru decorare. Căutați niște consolă și șuruburi (4 x 16 mm) pe care le veți găsi în punga KITENV. Înșurubați consola după cum doriți. În fotografia 23 aveți un exemplu. Două șuruburi pentru fiecare consolă sunt suficiente.

SV INSTALLATION AV STRUKTURSYSTEMET

Detta för att täcka de vertikala stolparna (foto 22) för att ge poolen en trevligare estetik. Denna bit är endast för dekoration. Leta efter några fästet och skruvar (4 x 16 mm) som du hittar i påsen KITENV. Skruva fast fästet som du föredrar. På foto 23 finns ett exempel. Två skruvar för varje fäste räcker.

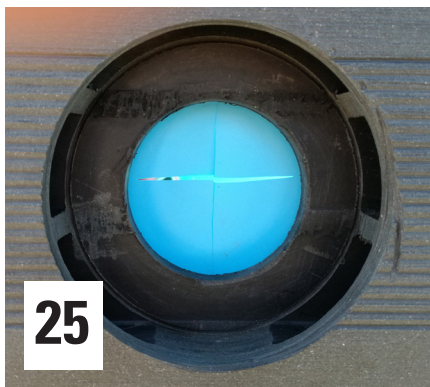

EN FITTING THE RETURN VALVE (V): (IMPELLER NOZZLE: V)

This valve is located at the bottom of the pool wall, and the water is returned to the pool through it after being treated in the treatment unit. Start pouring water into the pool through a garden hose, and stop 4 cm below the bottom of the valve hole. Mark the position of the hole on the liner with a felt pen and make a cross-shaped cut in the centre of the mark with a stanley knife or similar. Do not cut beyond the edge of the hole (Photo 25). The liner can also be cut before introducing the nozzle, making a circular cut supported at the back on a flat surface.

Locate two return valves of the skimmer box. One valve has a flat finish, which can be used with the hose provided in the kit of your pool. The other return valve has a threaded finish. This should be used if you want to install a semi-rigid PVC pipe (not included). In this case, you will need a coupling to change from 38 mm diameter to 50 mm diameter. This can be found in your nearest DIY store.

PL MONTAŻ ZAWORU ZWROTNEGO (V): (DYSZA WIRNIKA: V)

Zawór ten znajduje się w dolnej części ściany basenu i to przez niego woda wraca do basenu po przefiltrowaniu. Zaczynij wlewać wodę do basenu węzłem ogrodowym i zakręć ją na poziomie 4 cm poniżej dna otworu zaworu. Zaznacz położenie otworu na linerze za pomocą flamastra i wykonaj nacięcie w kształcie krzyża na środku znaku za pomocą noża Stanleya lub podobnego narzędzia. Nie wolno rozcinać lineru poza krawędzią otworu (zdjęcie nr 25). Liner można również przeciąć przed wprowadzeniem dyszy, wykonując okrągłe nacięcie, opierając go z tyłu na płaskiej powierzchni.

Znajdź dwa zawory zwrotne skrzynki skimmera. Jeden zawór ma płaskie wykończenie, które może być używane z węzłem dostarczonym w zestawie z basenem. Drugi zawór powrotny ma gwintowane wykończenie. Należy go użyć, jeśli chcesz zainstalować półsztywną rurę PVC (nie dołączoną do zestawu). W tym przypadku, aby zmienić średnicę z 38 mm na 50 mm, potrzebna będzie złączka. Można ją znaleźć w najbliższym sklepie dla majsterkowiczów.

CS FITTING THE RETURN VALVE (V): (IMPELLER NOZZLE: V)

This valve is located at the bottom of the pool wall, and the water is returned to the pool through it after being treated in the treatment unit. Start pouring water into the pool through a garden hose, and stop 4 cm below the bottom of the valve hole. Mark the position of the hole on the liner with a felt pen and make a cross-shaped cut in the centre of the mark with a stanley knife or similar. Do not cut beyond the edge of the hole (Photo 25). The liner can also be cut before introducing the nozzle, making a circular cut supported at the back on a flat surface.

Locate two return valves of the skimmer box. One valve has a flat finish, which can be used with the hose provided in the kit of your pool. The other return valve has a threaded finish. This should be used if you want to install a semi-rigid PVC pipe (not included). In this case, you will need a coupling to change from 38 mm diameter to 50 mm diameter. This can be found in your nearest DIY store.

SK FITTING THE RETURN VALVE (V): (IMPELLER NOZZLE: V)

This valve is located at the bottom of the pool wall, and the water is returned to the pool through it after being treated in the treatment unit. Start pouring water into the pool through a garden hose, and stop 4 cm below the bottom of the valve hole. Mark the position of the hole on the liner with a felt pen and make a cross-shaped cut in the centre of the mark with a stanley knife or similar. Do not cut beyond the edge of the hole (Photo 25). The liner can also be cut before introducing the nozzle, making a circular cut supported at the back on a flat surface.

Locate two return valves of the skimmer box. One valve has a flat finish, which can be used with the hose provided in the kit of your pool. The other return valve has a threaded finish. This should be used if you want to install a semi-rigid PVC pipe (not included). In this case, you will need a coupling to change from 38 mm diameter to 50 mm diameter. This can be found in your nearest DIY store.

RO MONTAREA SUPAPEI DE RETUR (V): (DUZA ROTORULUI: V)

Această supapă este situată în partea de jos a peretelui piscinei, iar apa este returnată în piscină prin ea după ce a fost tratată în unitatea de tratare. Începeți să turnați apă în piscină printr-un furtun de grădină și opriți-vă la 4 cm sub fundul orificiului supapei. Marcați poziția găurii de pe căptușeală cu un stilou și faceți o tăietură în formă de cruce în centrul marcajului cu un cuțit Stanley sau similar. Nu tăiați dincolo de marginea găurii (Foto 25). Căptușeala poate fi, de asemenea, tăiată înainte de a introduce duza, realizând o tăietură circulară susținută în spate pe o suprafață plană. Localizați două supape de retur ale cutiei de skimmer. O supapă are un finisaj plat, care poate fi utilizată cu furtunul furnizat în kitul piscinei dvs. Cealaltă supapă de retur are un finisaj filetat. Acest lucru trebuie utilizat dacă doriți să instalați o țeavă din PVC semi-rigidă (nu este inclusă). În acest caz, veți avea nevoie de un cuplaj pentru a trece de la 38 mm diametru la 50 mm diametru. Acest lucru poate fi găsit în cel mai apropiat magazin de bricolaj.

SV ONTERING AV RETURVENTILEN (V): (IMPELLER MUNSTYCKE: V)

Denna ventil är placerad längst ner på poolväggen och vattnet återförs till poolen genom den efter att ha behandlats i behandlingsenheten. Börja hälla vatten i poolen genom en trädgårdsslang och stoppa 4 cm under ventilhålets botten. Markera hålets position på linern med en filtpenna och gör ett korsformat snitt i mitten av märket med en stanleykniv eller liknande. Skär inte bortom hålets kant (Foto 25). Fodret kan också skäras innan munstycket införs, vilket gör en cirkelformad skärning bak på en plan yta.

Leta upp två returventiler i skimmerboxen. En ventil har en plan yta, som kan användas med slangen som medföljer i kiten för din pool. Den andra returventilen har en gängad yta. Detta bör användas om du vill installera ett halvstyvt PVC-rör (ingår ej). I det här fallet behöver du en koppling för att byta från 38 mm 21 diameter till 50 mm diameter. Detta finns i ditt närmaste byggvaruhus.



26



27



28

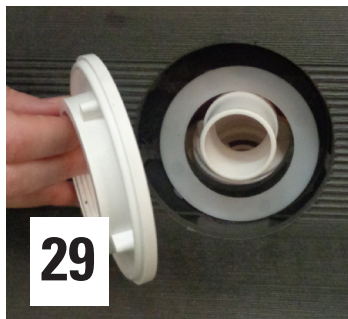

29



30

EN Insert the nozzle from the inside of the pool through the cut already made with a friction ring (F) and a gasket (J) once they are placed. This way, the gasket (J) is in contact with the liner. Cut the piece of the liner that is visible from the outside (Picture 26). The other gasket (J) is put into place from the outside, place it at the very back in contact with the liner (Photo 27). Place the other friction ring (F) (Photo 28) and tighten firmly with the nut (T). (Photo 29)
To properly insert the nut from the exterior, the person located inside the pool holding the return valve, should slightly move backwards to fix the nut with the composite form from the exterior. (photo 29 - 30)

PL Zainstaluj dyszę po wewnętrznej stronie basenu poprzez nacięcie wykonane wcześniej za pomocą pierścienia łożyskowego (F) i uszczelkę (J), założone uprzednio na dyszę. W ten sposób uszczelka (J) styka się z linerem. Obetnij widoczny z zewnątrz fragment lineru (zdjęcie nr 26). Drugą uszczelkę (J) zakładamy od zewnętrznej strony, z tyłu, tak aby stykała się z linerem (zdjęcie nr 27). Załóż drugi pierścień łożyskowy (F) (zdjęcie nr 28) i mocno dokręć nakrętkę (T). (Zdjęcie nr 29)
Aby prawidłowo założyć nakrętkę od strony zewnętrznej, osoba znajdująca się wewnątrz basenu, trzymająca zawór zwrotny, powinna lekko przesunąć się do tyłu, aby przymocować nakrętkę z kompozytem od strony zewnętrznej. (Zdjęcia nr 29 - 30)

CS Insert the nozzle from the inside of the pool through the cut already made with a friction ring (F) and a gasket (J) once they are placed. This way, the gasket (J) is in contact with the liner. Cut the piece of the liner that is visible from the outside (Picture 26). The other gasket (J) is put into place from the outside, place it at the very back in contact with the liner (Photo 27). Place the other friction ring (F) (Photo 28) and tighten firmly with the nut (T). (Photo 29)
To properly insert the nut from the exterior, the person located inside the pool holding the return valve, should slightly move backwards to fix the nut with the composite form from the exterior. (photo 29 - 30)

SK Insert the nozzle from the inside of the pool through the cut already made with a friction ring (F) and a gasket (J) once they are placed. This way, the gasket (J) is in contact with the liner. Cut the piece of the liner that is visible from the outside (Picture 26). The other gasket (J) is put into place from the outside, place it at the very back in contact with the liner (Photo 27). Place the other friction ring (F) (Photo 28) and tighten firmly with the nut (T). (Photo 29)
To properly insert the nut from the exterior, the person located inside the pool holding the return valve, should slightly move backwards to fix the nut with the composite form from the exterior. (photo 29 - 30)

RO Introduceți duza din interiorul bazinului prin tăietura deja realizată cu un inel de frecare (F) și o garnitură (J) odată ce sunt așezate. În acest fel, garnitura (J) este în contact cu căptușeala. Taiati bucata căptușelii care este vizibilă din exterior (Figura 26). Cealaltă garnitură (J) este pusă din exterior, așezați-o chiar în spate, în contact cu căptușeala (Foto 27). Așezați celălalt inel de frecare (F) (Foto 28) și strângeți-l ferm cu piulița (T). (Foto 29)
Pentru a introduce piulița în mod corespunzător din exterior, persoana aflată în interiorul bazinului care ține supapa de retur trebuie să se miște ușor înapoi pentru a fixa piulița cu compozitul din exterior. (foto 29 - 30)

SV För in munstycket från insidan av poolen genom det snitt som redan gjorts med en friktionsring (F) och en packning (J) när den har placerats. På detta sätt är packningen (J) i kontakt med linern. Klipp delen av linern som syns från utsidan (Bild 26). Den andra packningen (J) placeras på plats från utsidan, placera den längst bak i kontakt med linern (Foto 27). Placera den andra friktionsringen (F) (Foto 28) och dra åt ordentligt med muttern (T). (Foto 29)
För att sätta in muttern ordentligt från utsidan, ska personen som sitter inne i poolen som håller returventilen flytta något bakåt för att fästa muttern med kompositen från utsidan. (foto 29 - 30)



31

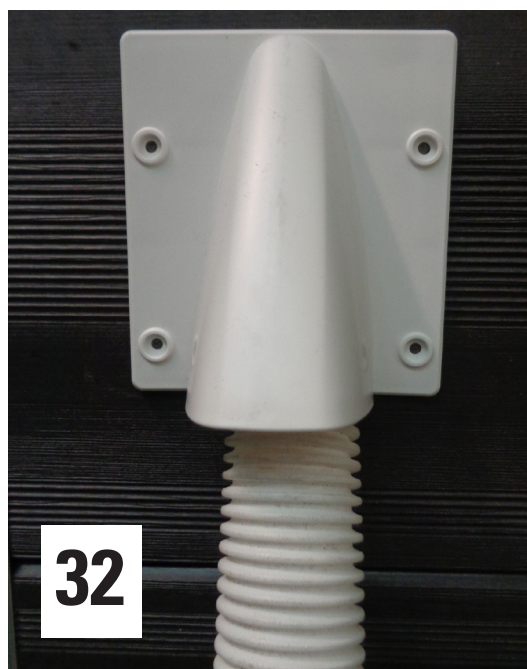

32

- EN** Insert the return hose (M) which goes from the outlet of the treatment unit to the return valve (V), and secure it with the clamp (A) (photo 31). When the filtering is working, the safety cover must be installed as seen in photo 32. Use the screws included in the kit.
Tip: You can use a 2 mm drill bit to make a guide on the panel, this way it is easier to screw it. It is advisable that it is attached once the filtration has begun. This way you can correct any problems you have with the filtration without needing to remove the trim.
- PL** Włóż wąż zwrotny (M), który biegnie od wylotu filtra do zaworu zwrotnego (V) i zabezpiecz go obejmą zaciskową (A) (zdjęcie nr 31). Gdy filtrowanie jest już w toku, należy zamontować pokrywę zabezpieczającą, tak jak pokazano na zdjęciu nr 32. Użyj do tego śrub znajdujących się w zestawie.
Wskazówka: Możesz użyć wiertła 2 mm, aby wykonać otwór w panelu – w ten sposób łatwiej będzie ją przykręcić. Panel należy zamocować po rozpoczęciu filtracji. W ten sposób można skorygować ewentualne problemy z filtracją bez konieczności demontażu listwy wykończeniowej.
- CS** Insert the return hose (M) which goes from the outlet of the treatment unit to the return valve (V), and secure it with the clamp (A) (photo 31). When the filtering is working, the safety cover must be installed as seen in photo 32. Use the screws included in the kit.
Tip: You can use a 2 mm drill bit to make a guide on the panel, this way it is easier to screw it. It is advisable that it is attached once the filtration has begun. This way you can correct any problems you have with the filtration without needing to remove the trim.
- SK** Insert the return hose (M) which goes from the outlet of the treatment unit to the return valve (V), and secure it with the clamp (A) (photo 31). When the filtering is working, the safety cover must be installed as seen in photo 32. Use the screws included in the kit.
Tip: You can use a 2 mm drill bit to make a guide on the panel, this way it is easier to screw it. It is advisable that it is attached once the filtration has begun. This way you can correct any problems you have with the filtration without needing to remove the trim.
- RO** Introduceți furtunul de retur (M) care merge de la ieșirea unității de tratament la supapa de retur (V) și fixați-l cu clema (A) (foto 31). Când filtrarea funcționează, capacul de siguranță trebuie instalat așa cum se vede în fotografia 32. Folosiți șuruburile incluse în kit.
Sfat: Puteți utiliza un burghiu de 2 mm pentru a face un ghidaj pe panou, astfel este mai ușor să îl înșurubați. Este recomandabil să fie atașat odată ce filtrarea a început. În acest fel, puteți corecta orice probleme pe care le aveți cu filtrarea fără a fi nevoie să scoateți ornamentul.
- SV** Sätt i returslangen (M) som går från behandlingsenhetens utlopp till returventilen (V) och fäst den med klämman (A) (foto 31). När filtreringen fungerar måste säkerhetsskyddet installeras som ses på foto 32. Använd skruvarna som ingår i kiten.
Dricks: Du kan använda en 2 mm borr för att skapa en guide på panelen, på det sättet är det lättare att skruva fast den. Det rekommenderas att det fästs när filtreringen har börjat. På så sätt kan du korrigerar eventuella problem med filtreringen utan att du behöver ta bort trimmen.

**33****34****35****36****EN ATTACHING THE SKIMMER BODY (S) TO THE OUTSIDE OF THE POOL:**

Fill the pool with water until it reaches 4 cm from the bottom of the die of the skimmer. Affix the seal ring and position the skimmer frame. Screw it with a screwdriver. Using a Stanley knife, cut the bit of the liner (L) that the skimmer frame covers (only the inside bit).

Finally, place the trim piece. Note that the trim has "max" and "min" markings. They indicate the maximum and the minimum level of water that your pool should have.

Cover the connecting bushing (C) and the water treatment unit with Teflon. Screw the connecting bushing (C) tightly to the skimmer and connect one end of the hose to the skimmer connecting bushing (C) using a clamp (A). Then fit the other end to the treatment unit and clamp it.

Important: Use Teflon on all water hose connection threads to ensure leak-tightness.

Locate the aluminium trim for the skimmer. To secure it to the panel, take 8 screws (4 x 16 mm) from the box: KITENV.....

PL PRZYMOCOWANIE SKIMMERA DO ZEWNĘTRZNEJ CZĘŚCI BASENU:

Napełnij basen wodą do wysokości 4 cm od dolnej krawędzi skimmera. Załóż uszczelkę i ustaw obudowę skimmera. Przykręć ją śrubokrętem. Przy pomocy noża Stanleya wykonaj otwór w linerze (L), wytnij tylko część którą przykrywa obudowa skimmera (tylko wewnętrzną część).

Na koniec załóż listwę wykończeniową. Zauważ, że listwa wykończeniowa ma oznaczenia „max” i „min”. Wskazują one maksymalny i minimalny poziom wody, który powinien znajdować się w basenie.

Następnie zaklej tuleję (C) i filtr za pomocą taśmy teflonowej. Przykręć mocno tuleję (C) do skimmera i podłącz jeden koniec węża do tulei skimmera (C) za pomocą obejmy zaciskowej (A). Następnie podłącz drugi koniec węża do otworu filtra i zaciśnij go.

Ważne: Zaklej taśmą teflonową wszystkie połączenia węża wodnego, aby zapewnić jego szczelność.

Załącz aluminiową listwę wykończeniową skimmera. Aby przymocować ją do panelu, należy wyjąć z pudełka 8 śrub (4 x 16 mm): KITENV.....

CS ATTACHING THE SKIMMER BODY (S) TO THE OUTSIDE OF THE POOL:

Fill the pool with water until it reaches 4 cm from the bottom of the die of the skimmer. Affix the seal ring and position the skimmer frame. Screw it with a screwdriver. Using a Stanley knife, cut the bit of the liner (L) that the skimmer frame covers (only the inside bit).

Finally, place the trim piece. Note that the trim has "max" and "min" markings. They indicate the maximum and the minimum level of water that your pool should have.

Cover the connecting bushing (C) and the water treatment unit with Teflon. Screw the connecting bushing (C) tightly to the skimmer and connect one end of the hose to the skimmer connecting bushing (C) using a clamp (A). Then fit the other end to the treatment unit and clamp it.

Important: Use Teflon on all water hose connection threads to ensure leak-tightness.

Locate the aluminium trim for the skimmer. To secure it to the panel, take 8 screws (4 x 16 mm) from the box: KITENV.....

SK ATTACHING THE SKIMMER BODY (S) TO THE OUTSIDE OF THE POOL:

Fill the pool with water until it reaches 4 cm from the bottom of the die of the skimmer. Affix the seal ring and position the skimmer frame. Screw it with a screwdriver. Using a Stanley knife, cut the bit of the liner (L) that the skimmer frame covers (only the inside bit).

Finally, place the trim piece. Note that the trim has "max" and "min" markings. They indicate the maximum and the minimum level of water that your pool should have.

Cover the connecting bushing (C) and the water treatment unit with Teflon. Screw the connecting bushing (C) tightly to the skimmer and connect one end of the hose to the skimmer connecting bushing (C) using a clamp (A). Then fit the other end to the treatment unit and clamp it.

Important: Use Teflon on all water hose connection threads to ensure leak-tightness.

Locate the aluminium trim for the skimmer. To secure it to the panel, take 8 screws (4 x 16 mm) from the box: KITENV.....

RO ATAȘAREA CORPULUI (LOR) DE SKIMMER LA EXTERIUL PISCINEI:

Umpleți piscina cu apă până când ajunge la 4 cm de fundul matriței skimmerului. Atașați inelul de etanșare și poziționați cadrul skimmer. Înșurubați-l cu o șurubelniță.

Folosind un cuțit Stanley, tăiați bitul căptușelii (L) pe care îl acoperă cadrul skimmerului (doar bitul interior).

În cele din urmă, așezați bucata de tăiere. Rețineți că ornamentul are marcate „max” și „min”. Acestea indică nivelul maxim și minim de apă pe care ar trebui să-l aibă piscina ta.

Acoperiți buca de conectare (C) și unitatea de tratare a apei cu teflon. Înșurubați bine buca de conectare (C) la skimmer și conectați un capăt al furtunului la buca de conectare a skimmerului (C) folosind o clemă (A). Apoi fixați celălalt capăt la unitatea de tratament și fixați-l.

Important: Utilizați teflon pe toate filetele de conectare a furtunului de apă pentru a asigura etanșeitatea.

Localizați garnitura de aluminiu pentru skimmer. Pentru a-l fixa pe panou, luați 8 șuruburi (4 x 16 mm) din cutie: KITENV

SV FÄSTA SKUMMERKROPPEN UTAN UTOM POOLEN:

Fyll poolen med vatten tills den når 4 cm från botten av skummets matris. Fäst tätningringen och placera skimmerramen. Skruva fast den med en skruvmejsel. Använd en Stanley-kniv och klipp av biten på linern (L) som skimmerramen täcker (endast insidan).

Slutligen placera trimstycket. Observera att trimmen har "max" och "min" markeringar. De anger den högsta och lägsta vattennivån som din pool ska ha. Täck

anslutningsbussningen (C) och vattenbehandlingsenheten med Teflon. Skruva fast anslutningsbussningen (C) ordentligt på skimmern och anslut ena änden av slangens till skummanslutningsbussningen (C) med en klämma (A). Montera sedan den andra änden på behandlingsenheten och kläm fast den.

Viktig: Använd teflon på alla vattenslangens anslutningsgångar för att säkerställa täthet.

Leta upp aluminiumbeklädnaden för skimmern. För att fästa den på panelen, ta 8 skruvar (4 x 16 mm) ur lådan: KITENV

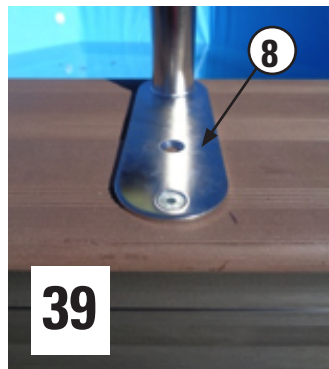
**EN****PLACEMENT OF THE INTERNAL LADDER**

- Take out the ladder and follow the installation instructions. Think about where you want to have the entry for your swimming pool. You can also mount it and put it into pool without attaching the fastenings to see how it looks. Just support it on the shore.
- Look for two metal plates. These parts are essential to correctly affix the ladder.
- Put them on place panels (photo 37) and make a hole from the bottom using the proper drill bit N° 10 (photo 38).
- Place part 8, the fastening, so that it coincides with the hole. Use the short bolt and secure it with a nut and washer. (photo 39).
- Finish securing the plate by making another hole and securing it with a long screw bolt. (photo 40).
- Once one of the ladder's fastenings is secured, introduce the other fastening. Make a mark where the screw hole should be made. This step is very important, as it must match the distance between the ladder rails.

PL**MONTAŻ DRABINKI WEWNĘTRZNEJ**

- Wyjmij drabinę z opakowania i postępuj zgodnie z instrukcją montażu. Zastanów się, gdzie chcesz mieć wejście do basenu. Możesz również założyć ją w basenie bez przykręcania, aby zobaczyć jak wygląda. Wystarczy podeprzeć ją na brzegu.
- Poszukaj dwóch metalowych blaszek. Elementy te są niezbędne do prawidłowego zamocowania drabinki.
- Przyłóż je do panelu (zdjęcie nr 37) i wykonaj otwór od spodu za pomocą wiertła nr 10 (zdjęcie nr 38).
- Następnie zamontuj część nr 8 (mocowanie) umieszczając ją tak, aby pokrywała się z otworem. Użyj krótkiej śruby i zabezpiecz ją uszczelką oraz nakrętką (zdjęcie nr 39).
- Dokończ mocowanie blaszki, wykonując kolejny otwór i zabezpieczając go długą śrubą (zdjęcie nr 40).
- Po zabezpieczeniu jednego z mocowań drabiny, wprowadzić drugie mocowanie. Zaznacz miejsce, w którym ma być wykonany otwór na śrubę. Ten krok jest bardzo ważny, gdyż musi on odpowiadać odległości pomiędzy poręczami drabinki.

CS**PLACEMENT OF THE INTERNAL LADDER**

- Take out the ladder and follow the installation instructions. Think about where you want to have the entry for your swimming pool. You can also mount it and put it into pool without attaching the fastenings to see how it looks. Just support it on the shore.
- Look for two metal plates. These parts are essential to correctly affix the ladder.
- Put them on place panels (photo 37) and make a hole from the bottom using the proper drill bit N° 10 (photo 38).
- Place part 8, the fastening, so that it coincides with the hole. Use the short bolt and secure it with a nut and washer. (photo 39).
- Finish securing the plate by making another hole and securing it with a long screw bolt. (photo 40).
- Once one of the ladder's fastenings is secured, introduce the other fastening. Make a mark where the screw hole should be made. This step is very important, as it must match the distance between the ladder rails.

SK**PLACEMENT OF THE INTERNAL LADDER**

- Take out the ladder and follow the installation instructions. Think about where you want to have the entry for your swimming pool. You can also mount it and put it into pool without attaching the fastenings to see how it looks. Just support it on the shore.
- Look for two metal plates. These parts are essential to correctly affix the ladder.
- Put them on place panels (photo 37) and make a hole from the bottom using the proper drill bit N° 10 (photo 38).
- Place part 8, the fastening, so that it coincides with the hole. Use the short bolt and secure it with a nut and washer. (photo 39).
- Finish securing the plate by making another hole and securing it with a long screw bolt. (photo 40).
- Once one of the ladder's fastenings is secured, introduce the other fastening. Make a mark where the screw hole should be made. This step is very important, as it must match the distance between the ladder rails.

RO**PLASAREA SCARII INTERNE**

- Scoateți scara și urmați instrucțiunile de instalare. Gândiți-vă unde doriți să aveți intrarea pentru piscina dvs. De asemenea, îl puteți monta și pune în piscină fără a atașa elementele de fixare pentru a vedea cum arată. Sprijină-l pe mal.
- Căutați două plăci metalice. Aceste părți sunt esențiale pentru fixarea corectă a scării.
- Puneți-le pe panourile de poziție (foto 37) și faceți o gaură de jos folosind burghiul corespunzător nr. 10 (foto 38).
- Așezați partea 8, fixarea, astfel încât să coincidă cu gaura. Folosiți șurubul scurt și fixați-l cu o piuliță și o șaibă. (foto 39).
- Finalizați fixarea plăcii făcând o altă gaură și fixând-o cu un șurub lung. (foto 40).
- Odată ce una dintre fixările scării este fixată, introduceți cealaltă fixare. Faceți un semn unde ar trebui să fie făcută gaura șurubului. Acest pas este foarte important, deoarece trebuie să se potrivească distanțele dintre șinele scării.

SV**PLACERING AV DEN INTERNA STIGEN**

- Ta ut stegen och följ installationsanvisningarna. Tänk på var du vill ha posten till din pool. Du kan också montera den och lägga den i poolen utan att fästa fästena för att se hur den ser ut. Stöd bara det på stranden.
- Leta efter två metallplattor. Dessa delar är viktiga för att korrekt fästa stegen.
- Placera dem på platspaneler (foto 37) och gör ett hål från botten med rätt borrkrona N° 10 (foto 38).
- Placera del 8, fästet, så att det sammanfaller med hålet. Använd den korta bulten och säkra den med en mutter och brickan. (foto 39).
- Sluta fästa plattan genom att göra ett nytt hål och fästa det med en lång skruvbult. (foto 40).
- När en av stegen är fäst, introducera den andra fästet. Markera var skruvhålet ska göras. Detta steg är mycket viktigt eftersom det måste matcha avståndet mellan stegen.



EN PLACEMENT OF THE EXTERNAL LADDER

- Remove the ladder from the box with great care. Look for 8 screws (4 x 25 mm) and two hooks in the box:

- Place the ladder against the pool wall (photo 41) and make a mark as shown (Photo 42). Measure 2 cm from the ladder and 1 cm from the marks of the panel. (photo 43). Here you will make the upper hole for the hook. It should look like the (photo 42).

Look for the hook and insert it as shown on photo 44. Follow the same procedure to secure it to the handrail (photo 43).

PL MONTAŻ DRABINKI ZEWNĘTRZNEJ

- Wyjmij drabinę z opakowania z zachowaniem szczególnej ostrożności. W pudełku znajduje się 8 śrub (4 x 25 mm) i dwa haki:

- Przyłóż drabinę do ściany basenu (zdjęcie nr 41) i wykonaj oznaczenia jak na rysunku (zdjęcie nr 42). Odmierz odległość 2 cm od drabinki i 1 cm od oznaczeń na panelu (zdjęcie nr 43). W tym miejscu należy wykonać górny otwór na hak. Powinien on wyglądać jak na zdjęciu nr 42.

Znajdź hak i włóż go tak, jak pokazano na zdjęciu nr 44. Postępuj w ten sam sposób, aby przymocować go do poręczy (zdjęcie nr 43).

CS PLACEMENT OF THE EXTERNAL LADDER

- Remove the ladder from the box with great care. Look for 8 screws (4 x 25 mm) and two hooks in the box.

- Place the ladder against the pool wall (photo 41) and make a mark as shown (Photo 42). Measure 2 cm from the ladder and 1 cm from the marks of the panel. (photo 43). Here you will make the upper hole for the hook. It should look like the (photo 42).

Look for the hook and insert it as shown on photo 44. Follow the same procedure to secure it to the handrail (photo 43).

SK PLACEMENT OF THE EXTERNAL LADDER

- Remove the ladder from the box with great care. Look for 8 screws (4 x 25 mm) and two hooks in the box.

- Place the ladder against the pool wall (photo 41) and make a mark as shown (Photo 42). Measure 2 cm from the ladder and 1 cm from the marks of the panel. (photo 43). Here you will make the upper hole for the hook. It should look like the (photo 42).

Look for the hook and insert it as shown on photo 44. Follow the same procedure to secure it to the handrail (photo 43).

RO PLASAREA SCARII EXTERNE

- Scoateți scara din cutie cu mare grijă. Căutați 8 șuruburi (4 x 25 mm) și două cârlige în cutie.

- Așezați scara de peretele bazinului (foto 41) și marcați-o așa cum se arată (fotografia 42). Măsurați la 2 cm de scară și la 1 cm de semnele panoului. (foto 43). Aici veți face gaura superioară pentru cârlig. Ar trebui să arate ca (foto 42).

- Căutați cârligul și introduceți-l așa cum se arată în fotografia 44. Urmați aceeași procedură pentru a-l fixa de balustradă (foto 43).

SV PLACERING AV DEN EXTERNA STIGEN

- Ta bort stegen ur lådan med stor försiktighet. Leta efter 8 skruvar (4 x 25 mm) och två krokar i lådan.

- Placera stegen mot poolväggen (foto 41) och markera som visas (foto 42). Mät 2 cm från stegen och 1 cm från panelens märken. (foto 43). Här gör du det övre hålet för kroken. Det ska se ut som (foto 42).

Leta efter kroken och sätt in den som visas på foto 44. Följ samma procedur för att fästa den i ledstången (foto 43).

EN NOTE 1:
KPCOR60L : Your pool consists of 10 standard panels, 1 filtration panel and one led panel. We recommend one of these 4 options at the time of placing the led panel. This way, the light will spread throughout the pool evenly.

PL UWAGA 1:
KPCOR60L : Twój basen składa się z 10 standardowych paneli, 1 panelu z filtrem i 1 panelu z projektorem LED. Zalecamy jedną z poniższych 4 opcji w momencie zakładania panelu z projektorem LED. W ten sposób światło będzie równomiernie rozprzestrzeniało się po całym basenie.

CS NOTE 1:
KPCOR60L :Your pool consists of 10 standard panels, 1 filtration panel and one led panel. We recommend one of these 4 options at the time of placing the led panel. This way, the light will spread throughout the pool evenly.

SK NOTE 1:
KPCOR60L : Your pool consists of 10 standard panels, 1 filtration panel and one led panel. We recommend one of these 4 options at the time of placing the led panel. This way, the light will spread throughout the pool evenly.

RO NOTA 1:
KPCOR60L : Piscina dvs. este formată din 10 panouri standard, 1 panou de filtrare și un panou cu led. Vă recomandăm una dintre aceste 4 opțiuni în momentul plasării panoului led. În acest fel, lumina se va răspândi uniform în toată piscina.

SV ANTECKNING 1:
KPCOR60L : in pool består av 10 standardpaneler, 1 filtreringspanel och en LED-panel. Vi rekommenderar ett av dessa fyra alternativ när ledpanelen placeras. På detta sätt kommer ljuset att spridas jämnt i poolen.

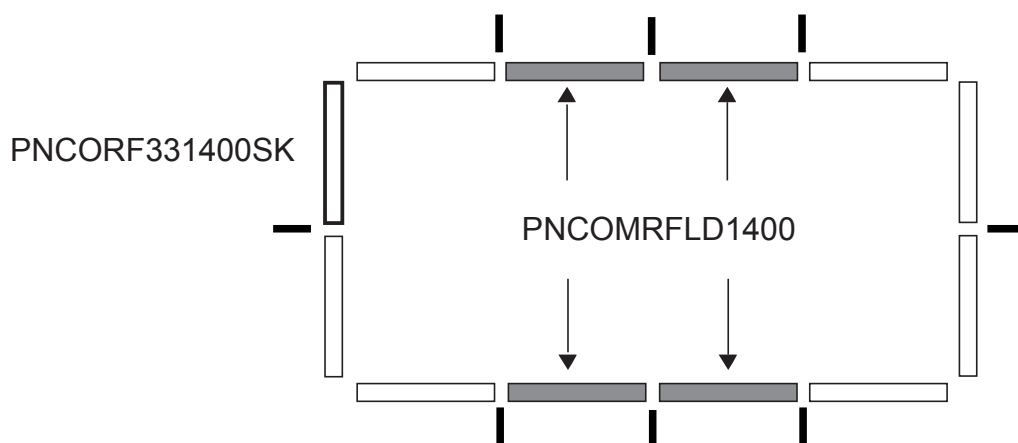

EN

**NOTE 2:
INSTALLATION OF THE LED PROJECTOR STRUCTURAL SYSTEM**

It is about covering the led projector and the cable as we did for covering the structural system. Locate the piece and put it as shown in picture A.

The structural system is composed of 4 brackets and its respective screws.

ATTENTION! It is very important to place the brackets IN THE STRIPPED AREA of the panel as shown in picture B. If, for the contrary, you try to screw the brackets on the flat surface, you won't be able to screw them properly and the panel may damage.

PL

**UWAGA 2:
INSTALACJA SYSTEMU STRUKTURALNEGO PROJEKTORA LED**

Chodzi tutaj o zakrycie projektora led i kabla, tak jak zrobiliśmy to w przypadku zakrywania systemu strukturalnego. Znajdź element i umieść go tak, jak pokazano na rysunku A.

System strukturalny składa się z 4 zawiasów i odpowiednich śrub.

UWAGA! Bardzo ważne jest, aby umieścić wsporniki na ŚCIĘTYM OBSZARZE panelu, jak pokazano na rysunku B. W przeciwnym razie, będziesz próbował przykręcić wsporniki na płaskiej powierzchni i nie będziesz w stanie przykręcić ich prawidłowo – panel może zostać uszkodzony.

CS

**NOTE 2:
INSTALLATION OF THE LED PROJECTOR STRUCTURAL SYSTEM**

It is about covering the led projector and the cable as we did for covering the structural system. Locate the piece and put it as shown in picture A.

The structural system is composed of 4 brackets and its respective screws.

ATTENTION! It is very important to place the brackets IN THE STRIPPED AREA of the panel as shown in picture B. If, for the contrary, you try to screw the brackets on the flat surface, you won't be able to screw them properly and the panel may damage.

SK

**NOTE 2:
INSTALLATION OF THE LED PROJECTOR STRUCTURAL SYSTEM**

It is about covering the led projector and the cable as we did for covering the structural system. Locate the piece and put it as shown in picture A.

The structural system is composed of 4 brackets and its respective screws.

ATTENTION! It is very important to place the brackets IN THE STRIPPED AREA of the panel as shown in picture B. If, for the contrary, you try to screw the brackets on the flat surface, you won't be able to screw them properly and the panel may damage.

RO

**NOTA 2:
INSTALAREA SISTEMULUI STRUCTURAL DE PROIECTOR LED**

Este vorba de acoperirea protectorului cu led și a cablului, așa cum am făcut pentru acoperirea sistemului structural. Localizați piesa și puneți-o așa cum se arată în imaginea A.

Sistemul structural este compus din 4 consolă și șuruburile respective.

ATENȚIE! Este foarte important să plasați consolele ÎN ZONA CU DĂRE ale panoului, așa cum se arată în imaginea B. Dacă, dimpotrivă, încercați să înșurubați consolele pe suprafața plană, nu veți putea să le înșurubați corect și panoul poate deteriora.

SV

**ANTECKNING 2:
INSTALLATION AV LED-PROJEKTORENS STRUKTURSISTEM**

Det handlar om att täcka den ledna projektorn och kabeln som vi gjorde för att täcka det strukturella systemet. Leta reda på biten och lägg den som visas i bild A. Struktursystemet består av fyra fästen och dess respektive skruvar.

UPPMÄRKSAMHET! Det är mycket viktigt att placera fästena INOM FÄRGET OMRÅDET på panelen som visas på bild B. Om du tvärtom försöker skruva fast fästena på den plana ytan kommer du inte att kunna skruva fast dem ordentligt och panelen kan skada.

UPPMÄRKSAMHET! Det är mycket viktigt att placera fästena INOM FÄRGET OMRÅDET på panelen som visas på bild B. Om du tvärtom försöker skruva fast fästena på den plana ytan kommer du inte att kunna skruva fast dem ordentligt och panelen kan skada.

A

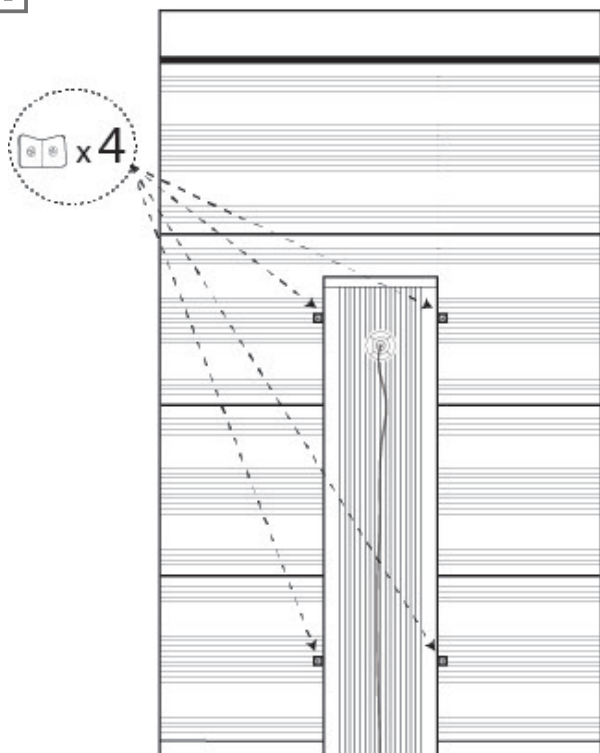

B

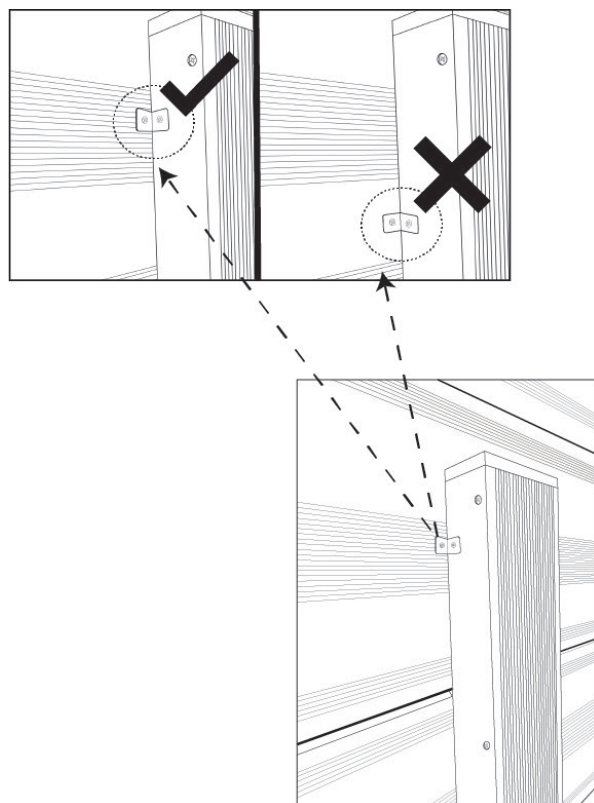

EN FILTER

PL FILTR

CS FILTER

SK FILTER

RO FILTRUL

SV FILTRERA

EN ASSEMBLY SUGGESTIONS: • The filter should be located at least 3.50 m from the pool.
The following diagrams explain the movement direction of the water. Check the manual that comes with the filter group for the assembly instructions.
Note: Fill the filter with 2/3 of clean, calibrated sand: only one calibration is supplied guaranteeing good use of the filter. (1) The colours and connections of the filter can vary according to models. Check the specific manual

 The multi-directional flap determines the flow direction. The marks "PUMP", "RETURN", "WASTE" are engraved on the inlets and outlets of the pump. The installation of all the electrical systems should comply with the NF-C15-100 regulation. Check with the manufacturer for any modification of one or several filter system components. The suction pump should not be situated above the water level, because there is a risk of becoming deactivated.

PL WSKAZÓWKI MONTAŻOWE: • Filtr powinien zostać umieszczony w odległości co najmniej 3,50 m od basenu.
Na poniższych rysunkach wyjaśniono kierunek ruchu wody. Sprawdź wskazówki znajdujące się w instrukcji montażu dołączonej do filtrów. Uwaga: Napełnij 2/3 filtra czystym, skalibrowanym piaskiem: dostarczana jest tylko jedna kalibracja gwarantująca odpowiednie użytkowanie filtra. (1) Kolory i połączenia filtra mogą się różnić w zależności od modelu. Sprawdź w odpowiedniej instrukcji obsługi

 Wielokierunkowa klapa określa kierunek przepływu. Oznaczenia „PUMP” (pompa), „RETURN” (zwrot), „WASTE” (odpady) są wygrawerowane na wlotach i wylotach pompy. Instalacja wszystkich systemów elektrycznych powinna zostać przeprowadzona zgodnie z przepisami NF-C15-100. Wszelkie modyfikacje jednego lub kilku elementów systemu filtracyjnego należy skonsultować z producentem. Pompa ssąca nie powinna znajdować się powyżej poziomu wody, ponieważ istnieje ryzyko jej wyłączenia.

CS ASSEMBLY SUGGESTIONS: • The filter should be located at least 3.50 m from the pool.
The following diagrams explain the movement direction of the water. Check the manual that comes with the filter group for the assembly instructions. Note: Fill the filter with 2/3 of clean, calibrated sand: only one calibration is supplied guaranteeing good use of the filter. (1) The colours and connections of the filter can vary according to models. Check the specific manual

 The multi-directional flap determines the flow direction. The marks "PUMP", "RETURN", "WASTE" are engraved on the inlets and outlets of the pump. The installation of all the electrical systems should comply with the NF-C15-100 regulation. Check with the manufacturer for any modification of one or several filter system components. The suction pump should not be situated above the water level, because there is a risk of becoming deactivated.

SK ASSEMBLY SUGGESTIONS: • The filter should be located at least 3.50 m from the pool.
The following diagrams explain the movement direction of the water. Check the manual that comes with the filter group for the assembly instructions. Note: Fill the filter with 2/3 of clean, calibrated sand: only one calibration is supplied guaranteeing good use of the filter. (1) The colours and connections of the filter can vary according to models. Check the specific manual

 The multi-directional flap determines the flow direction. The marks "PUMP", "RETURN", "WASTE" are engraved on the inlets and outlets of the pump. The installation of all the electrical systems should comply with the NF-C15-100 regulation. Check with the manufacturer for any modification of one or several filter system components. The suction pump should not be situated above the water level, because there is a risk of becoming deactivated.

RO SUGESTII DE ASAMBLARE: • Filtrul trebuie amplasat la cel puțin 3,50 m de piscină.
Următoarele diagrame explică direcția de mișcare a apei. Verificați manualul care vine cu grupul de filtrare pentru instrucțiunile de asamblare. Notă: Umpleți filtrul cu 2/3 de nisip curat, calibrat: este furnizată o singură calibrare care garantează o bună utilizare a filerului. (1) Culorile și conexiunile filtrului pot varia în funcție de modele. Verificați manualul specific

 Clapeta multidirecțională determină direcția de curgere. Marcajele „PUMP”, „RETURN”, „WASTE” sunt gravate pe intrările și ieșirile pompei. Instalarea tuturor sistemelor electrice trebuie să fie conformă cu reglementarea NF-C15-100. Consultați producătorul pentru orice modificare a uneia sau mai multor componente ale sistemului de filtrare. Pompa de aspirație nu trebuie amplasată deasupra nivelului apei, deoarece există riscul de a fi dezactivată.

SV MONTERINGSFÖRSLAG: • Filtret ska placeras minst 3,50 m från poolen.
Följande diagram förklarar vattnets rörelseriktning. Kontrollera manualen som medföljer filtergruppen för monteringsanvisningarna. Notera: Fyll filtret med 2/3 ren, kalibrerad sand: endast en kalibrering tillhandahålls som garanterar en god användning av filtret. (1) Färgerna och anslutningarna på filtret kan variera beroende på modell. Kontrollera den specifika manualen.

 Flervägsfliken bestämmer flödesriktningen. Markeringarna «PUMP», «RETURN», «AVFALL» är graverade på pumpens in- och utlopp. De installation av alla lektriska system ska uppfylla NF-C15-100-förordningen. Kontrollera med tillverkaren om det finns några ändringar av en eller flera filtersystemkomponenter. Sugumpen bör inte placeras ovanför vattennivån, eftersom det finns en risk att bli avaktiverad.

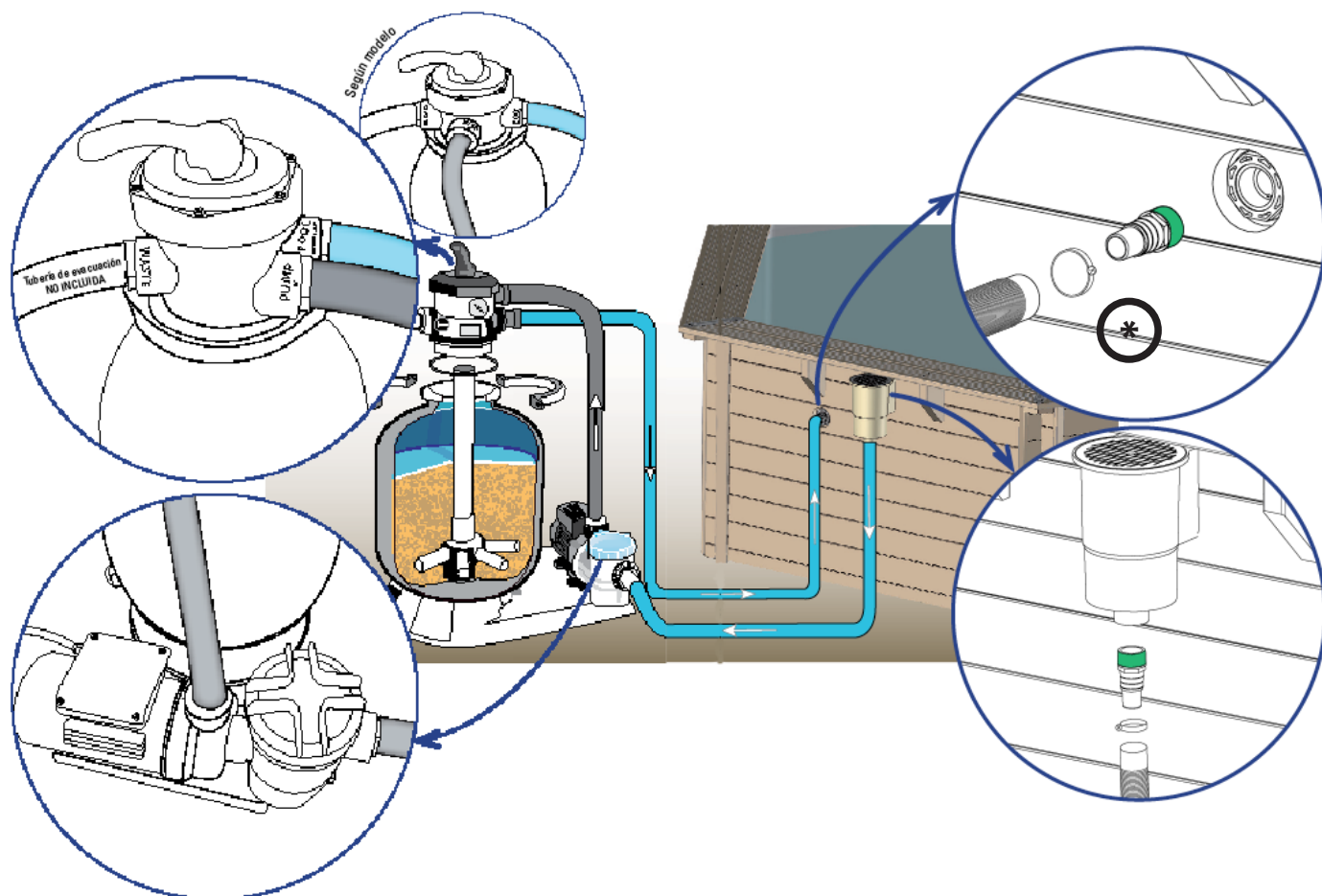

EN All the threaded connections should be assembled with the watertight Teflon tape *, except the connection with O rings. The Teflon should be wound round the thread in a counter clockwise direction.
LAND-FILLING: Finish filling the pool. The water level should be situated between the upper third part and the second half of the skimmer mouth.

PL Wszystkie połączenia gwintowane powinny być montowane z użyciem wodoszczelnej taśmy teflonowej *, z wyjątkiem połączeń typu O-ring. Taśmę teflonową należy owinąć wokół gwintu w kierunku przeciwnym do ruchu wskazówek zegara.
NAPEŁNIANIE BASENU: Na koniec należy napęlić basen wodą. Poziom wody powinien znajdować się pomiędzy górną trzecią częścią a drugą połową otworu skimmera.

CS All the threaded connections should be assembled with the watertight Teflon tape *, except the connection with O rings. The Teflon should be wound round the thread in a counter clockwise direction.
LAND-FILLING: Finish filling the pool. The water level should be situated between the upper third part and the second half of the skimmer mouth.

SK All the threaded connections should be assembled with the watertight Teflon tape *, except the connection with O rings. The Teflon should be wound round the thread in a counter clockwise direction.
LAND-FILLING: Finish filling the pool. The water level should be situated between the upper third part and the second half of the skimmer mouth.

RO Toate conexiunile filetate trebuie asamblate cu banda etanșă din teflon *, cu excepția conexiunii cu inele O. Teflonul trebuie înfășurat în jurul firului în sens invers acelor de ceasornic.
UMPLEREA TERENULUI: Terminați umplerea bazinului Nivelul apei trebuie situat între partea a treia superioară și a doua jumătate a gurii skimmerului.

SV Alla gängade anslutningar ska monteras med det vattentäta teflontejpen *, utom anslutningen med O-ringar. Teflonen ska lindas runt tråden moturs.
LANDFYLLNING: Slutför fyllningen av poolen. Vattennivån ska placeras mellan den övre tredje delen och den andra halvan av skummynningen.

EN SAND FILTER

PL FILTR PIASKOWY

CS SAND FILTER

SK SAND FILTER

RO FILTRUL DE NISIP

SV SANDFILTER

EN This is the oldest of filtering systems. The filtered water passes through the sand (calibrated silicon) that retains all impurities. This type of filter is equipped with a multi-directional flap that allows easy manipulations and cleaning.

DIFFERENT POSITIONS OF THE MULTI-DIRECTIONAL FLAP (4 OR 6)*: When you perform changes the position of the multi-directional flap that pump should always be stopped, without risking seriously damaging the filter and cancelling the guarantee.

1. FILTERING POSITION (OR FILTER): Usual position of the flap that allows the water coming from the pump to enter through the upper part of the filter and circulate through the same, where all its impurities are trapped. The water is collected in the mesh at the bottom and returned to the pool. The pressure gauge situated at the upper part of the filter allows controlling the pressure. In the case that the pressure increase 0.2 bar regarding the starting pressure, you will need to clean the filter.

PL Jest to najstarszy z systemów filtrujących. Przefiltrowana woda przechodzi przez piasek (kalibrowany silikon), który zatrzymuje wszystkie zanieczyszczenia. Ten rodzaj filtra wyposażony jest w wielokierunkową klapkę, która umożliwia łatwe manipulowanie i czyszczenie.

RÓŻNE POZYCJE WIELOKIERUNKOWEJ KLAPKI (4 LUB 6)*: W celu zmiany położenia klapki wielokierunkowej należy zawsze zatrzymać pompę, aby zapobiec poważnym uszkodzeniom filtra i unieważnieniu gwarancji.

1. POZYCJA FILTROWANIA (LUB FILTR): Normalna pozycja klapki pozwala wodzie wychodzącej z pompy przedostać się przez górną część filtra i cyrkulować przez niego, gdzie zatrzymywane są wszystkie jej zanieczyszczenia. Woda jest zbierana w siatce na dnie i zwracana do basenu. Manometr umieszczony w górnej części filtra umożliwia kontrolę ciśnienia. W przypadku, gdy ciśnienie wzrośnie o 0,2 bar w stosunku do ciśnienia początkowego, konieczne będzie wyczyszczenie filtra.

CS This is the oldest of filtering systems. The filtered water passes through the sand (calibrated silicon) that retains all impurities. This type of filter is equipped with a multi-directional flap that allows easy manipulations and cleaning.

DIFFERENT POSITIONS OF THE MULTI-DIRECTIONAL FLAP (4 OR 6)*: When you perform changes the position of the multi-directional flap that pump should always be stopped, without risking seriously damaging the filter and cancelling the guarantee.

1. FILTERING POSITION (OR FILTER): Usual position of the flap that allows the water coming from the pump to enter through the upper part of the filter and circulate through the same, where all its impurities are trapped. The water is collected in the mesh at the bottom and returned to the pool. The pressure gauge situated at the upper part of the filter allows controlling the pressure. In the case that the pressure increase 0.2 bar regarding the starting pressure, you will need to clean the filter.

SK This is the oldest of filtering systems. The filtered water passes through the sand (calibrated silicon) that retains all impurities. This type of filter is equipped with a multi-directional flap that allows easy manipulations and cleaning.

DIFFERENT POSITIONS OF THE MULTI-DIRECTIONAL FLAP (4 OR 6)*: When you perform changes the position of the multi-directional flap that pump should always be stopped, without risking seriously damaging the filter and cancelling the guarantee.

1. FILTERING POSITION (OR FILTER): Usual position of the flap that allows the water coming from the pump to enter through the upper part of the filter and circulate through the same, where all its impurities are trapped. The water is collected in the mesh at the bottom and returned to the pool. The pressure gauge situated at the upper part of the filter allows controlling the pressure. In the case that the pressure increase 0.2 bar regarding the starting pressure, you will need to clean the filter.

RO Acesta este cel mai vechi sistem de filtrare. Apa filtrată trece prin nisip (siliciu calibrat) care reține toate impuritățile. Acest tip de filtru este echipat cu o clapă multidirecțională care permite manipularea și curățarea ușoară.

POZIȚII DIFERITE ALE CLAPEI MULTI-DIRECȚIONALE (4 SAU 6)*: Când efectuați modificări, poziția clapetei multidirecționale trebuie să oprească întotdeauna pompa, fără a risca deteriorarea gravă a filtrului și anularea garanției.

1. POZIȚIA DE FILTRARE (SAU FILTRU): Poziția obișnuită a clapetei care permite apei care vine din pompă să pătrundă prin partea superioară a filtrului și să circule prin vană, unde sunt captate toate impuritățile sale. Apa este colectată în plasă în partea de jos și returnată la piscină. Manometrul situat în partea superioară a filtrului permite controlul presiunii. În cazul în care presiunea crește cu 0,2 bari în ceea ce privește presiunea de pornire, va trebui să curățați filtrul.

SV Detta är det äldsta filteringsystemet. Det filterade vattnet passerar genom sanden (kalibrerat kisel) som behåller alla orenheter. Denna typ av filter är utrustad

med en flervägsflik som möjliggör enkel hantering och rengöring.

OLIKA POSITIONER AV DEN MÄRRETNINGSLÅDA (4 ELLER 6)*: När du spelar ändrar positionen för flervägsklaffen att pumpen alltid ska stoppas utan att riskera att skada filtret allvarligt och upphäva garantin.

1. FILTERINGSPOSITION (ELLER FILTER): Vanligt läge för klaffen som gör att vattnet som kommer från pumpen kan tränga in genom filtrets övre del och cirkulera genom sundet, där alla dess föroreningar fastnar. Vattnet samlas i nätet längst ner och återförs till poolen. Tryckmätaren placerad vid den övre delen av filtret gör det möjligt att kontrollera trycket. Om trycket ökar med 0,2 bar avseende starttrycket måste du rengöra filtret.

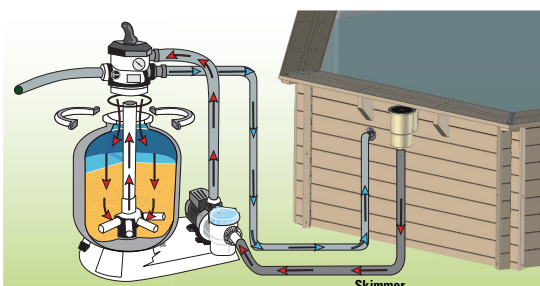
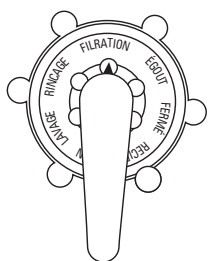

EN 2. WASHING POSITION (OR BACKWASH): Sand washing position. Allow the water to circulate in reverse direction in the filter. The water enters through the lower part of the filter elevates the filtering mass and therefore collects all its impurities and because they are lighter than sand, they are evacuated through the upper part of the filter towards the drain. This operation should last between 2 and 3 minutes.

PL 2. POZYCJA CZYSZCZENIA (LUB CZYSZCZENIE WSTECZNE): Pozycja czyszczenia piasku. Pozwala wodzie krążyć w filtrze w odwrotnym kierunku. Woda wpływająca przez dolną część filtra podnosi masę filtrującą i w ten sposób zbiera wszystkie zanieczyszczenia, a ponieważ są one lżejsze od piasku, są odprowadzane przez górną część filtra w kierunku odpływu. Proces ten powinien trwać od 2 do 3 minut.

CS 2. WASHING POSITION (OR BACKWASH): Sand washing position. Allow the water to circulate in reverse direction in the filter. The water enters through the lower part of the filter elevates the filtering mass and therefore collects all its impurities and because they are lighter than sand, they are evacuated through the upper part of the filter towards the drain. This operation should last between 2 and 3 minutes.

SK 2. WASHING POSITION (OR BACKWASH): Sand washing position. Allow the water to circulate in reverse direction in the filter. The water enters through the lower part of the filter elevates the filtering mass and therefore collects all its impurities and because they are lighter than sand, they are evacuated through the upper part of the filter towards the drain. This operation should last between 2 and 3 minutes.

RO 2. POZIȚIA DE SPĂLARE (SAU SPALAREA ULTERIOARĂ): Poziția de spălare cu nisip. Lăsați apa să circule în sens invers în filtru. Apa pătrunde prin partea inferioară a filtrului ridică masa filtrantă și, prin urmare, colectează toate impuritățile sale și, deoarece sunt mai ușoare decât nisipul, acestea sunt evacuate prin partea superioară a filtrului spre canalul de scurgere. Această operațiune ar trebui să dureze între 2 și 3 minute.

SV 2. Tvättposition (ELLER BACKWASH): Sandtvättposition. Låt vattnet cirkulera i omvänd riktning i filtret. Vattnet tränger in genom den nedre delen av filtret höjer filtreringsmassan och samlar därför alla dess föroreningar och eftersom de är lättare än sand evakueras de genom den övre delen av filtret mot avloppet. Den här åtgärden ska ta mellan 2 och 3 minuter.

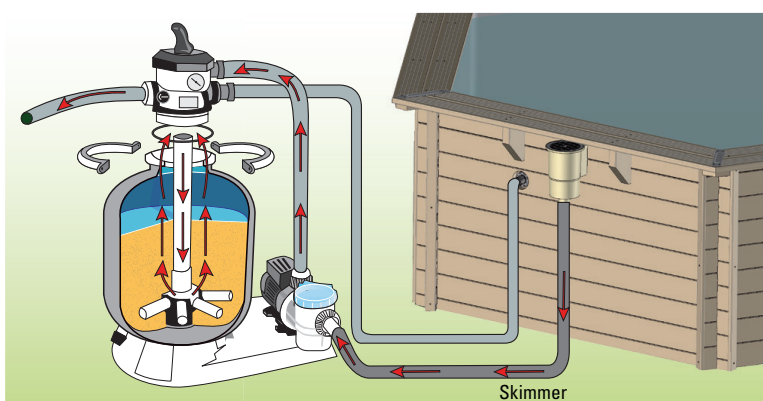
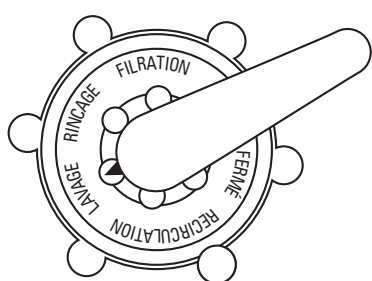

EN 3. RINSE POSITION / DRAINING OF THE FILTER (OR RINSE):** Operation that follows washing the filter. When you have cleaned the filter, you should rinse and re-compress the filtering mass. In this position the water circulates through the filter as in the filtering position but is evacuated through the drain at the filter outlet. This operation should be performed between 20 and 30 seconds.

PL 3. POZYCJA PŁUKANIA / OPRÓŻNIANIA FILTRA (LUB PŁUKANIE):** Proces, który następuje po umyciu filtra. Po wyczyszczeniu filtra należy przepłukać i ponownie zagęścić masę filtracyjną. W tej pozycji woda krąży przez filtr tak jak w pozycji filtrowania, ale jest odprowadzana przez spust na wylocie filtra. Czynność trwa od 20 do 30 sekund.

CS 3. RINSE POSITION / DRAINING OF THE FILTER (OR RINSE):** Operation that follows washing the filter. When you have cleaned the filter, you should rinse and re-compress the filtering mass. In this position the water circulates through the filter as in the filtering position but is evacuated through the drain at the filter outlet. This operation should be performed between 20 and 30 seconds.

SK 3. RINSE POSITION / DRAINING OF THE FILTER (OR RINSE):** Operation that follows washing the filter. When you have cleaned the filter, you should rinse and re-compress the filtering mass. In this position the water circulates through the filter as in the filtering position but is evacuated through the drain at the filter outlet. This operation should be performed between 20 and 30 seconds.

RO 3. POZIȚIA DE CLATIRE / SCURGEREA FILTRULUI (SAU CLĂȚIREA):** Operație care urmează spălării filtrului. După ce ați curățat filtrul, trebuie să clățiți și să comprimați din nou masa de filtrare. În această poziție apa circulă prin filtru ca și în poziția de filtrare, dar este evacuată prin canalul de scurgere la ieșirea filtrului. Această operație trebuie efectuată între 20 și 30 de secunde.

SV 3. SKÖLLPOSITION / TÖMNING AV FILTER ** (ELLER SKÖLJNING): Funktion som följer efter tvätt av filtret. När du har rengjort filtret ska du skölja och komprimera filtreringsmassan igen. I detta läge cirkulerar vattnet genom filtret som i filtreringsläget men evakueras genom avloppet vid filterutloppet. Denna åtgärd ska utföras mellan 20 och 30 sekunder.

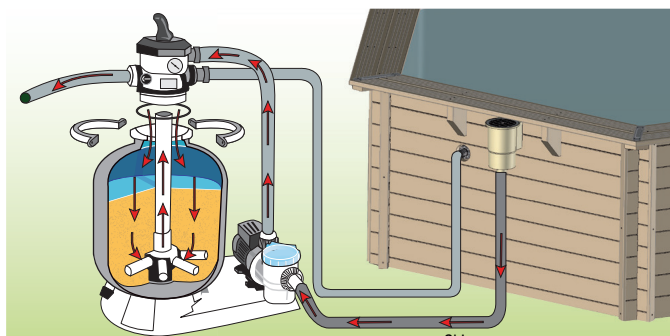
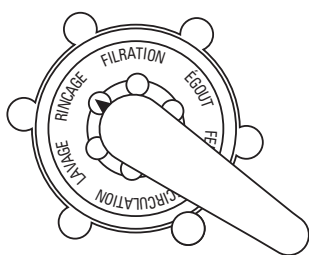

- EN 4. EMPTYING POSITION / DRAIN (OR WASTE):** Position to evacuate the water of for emptying the pool. In this case, the water does not pass through the filter, it goes directly to the drain.
- PL 4. POZYCJA OPRÓŻNIANIA / ODPŁYWU (LUB ODPADY):** Pozycja odpływu wody w celu opróżnienia basenu. W tym przypadku woda nie przechodzi przez filtr, lecz trafia bezpośrednio do odpływu.
- CS 4. EMPTYING POSITION / DRAIN (OR WASTE):** Position to evacuate the water of for emptying the pool. In this case, the water does not pass through the filter, it goes directly to the drain.
- SK 4. EMPTYING POSITION / DRAIN (OR WASTE):** Position to evacuate the water of for emptying the pool. In this case, the water does not pass through the filter, it goes directly to the drain.
- RO 4. POZIȚIA DE GOLIRE / SCURGERE (SAU ELIMINARE):** PoziȚia de evacuare a apei pentru golirea bazinului. În acest caz, apa nu trece prin filtru, ea merge direct la canalizare.
- SV TÖMNINGSPOSITION / AVLOPP (ELLER AVFALL):** Position för att evakuera vattnet för att tömma poolen. I detta fall passerar vattnet inte genom filtret, det går direkt till avloppet.

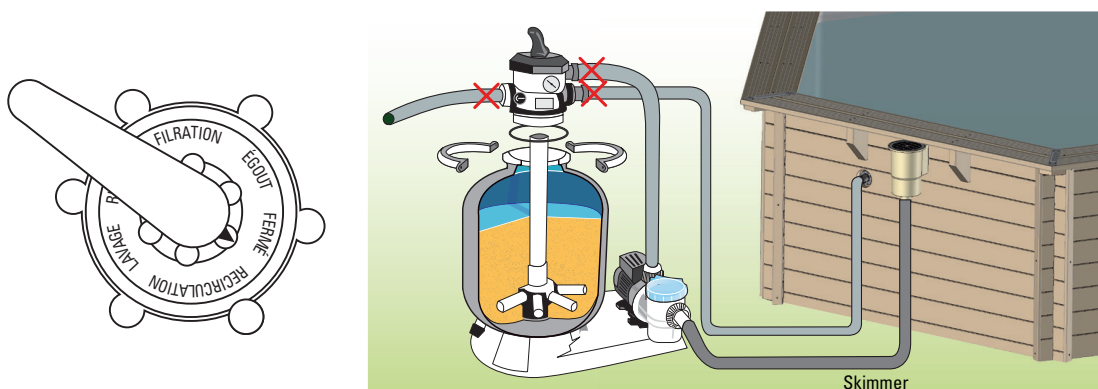

- EN 5. CLOSED POSITION (OR CLOSED):** This position does not allow the water to pass and is used to put the pool into complete wintering when the filtering stops.
- PL 5. POZYCJA ZAMKNIĘCIA (LUB ZAMKNIĘTA):** Pozycja ta uniemożliwia przepływ wody i służy do całkowitego przezimowania basenu, po zatrzymaniu filtrowania.
- CS 5. CLOSED POSITION (OR CLOSED):** This position does not allow the water to pass and is used to put the pool into complete wintering when the filtering stops.
- SK 5. CLOSED POSITION (OR CLOSED):** This position does not allow the water to pass and is used to put the pool into complete wintering when the filtering stops.
- RO 5. POZIȚIA ÎNCHISĂ (SAU BLOCATĂ):** Această poziȚie nu permite trecerea apei și este utilizată pentru a pune piscina în iernare completă când filtrarea se oprește.
- SV 5. TÄNGD POSITION (ELLER STÄNGD):** Denna position tillåter inte vattnet att passera och används för att sätta poolen i fullständig övervintring när filtreringen slutar.

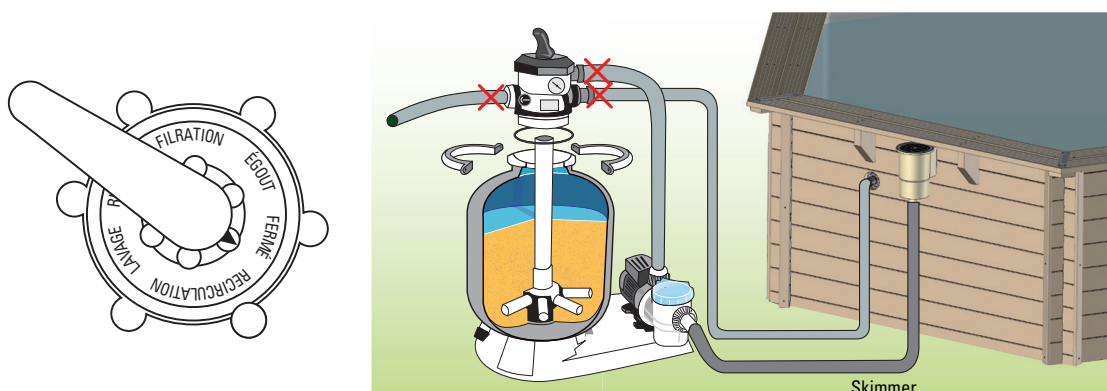

EN 6. RECIRCULATION POSITION / CIRCULATION:** Position used so the water circulates through the hydraulic network without passing through the filter. This possibility is used to move the water if you want to add a product to the pool or if you should perform any operation in the filter, because in this case the filter is isolated and the water coming from the pump is directly expelled.

* Some models are delivered with 4-way flap (available options: Filtering, Washing, Emptying/drain Closed or wintering).

** These positions refer exclusively to the 6-way flap.

PL 6. POZYCJA RECYRKULACJI / CYRKULACJI:** Pozycja umożliwiająca krążenie wody w sieci hydraulicznej bez przechodzenia przez filtr. Opcja ta ma na celu przemieszczanie wody, jeśli chcesz dodać produkt do basenu lub jeśli musisz wykonać jakąkolwiek czynność w filtrze, ponieważ w ten sposób filtr zostaje odizolowany, a woda pochodząca z pompy jest bezpośrednio wydalana.

* Niektóre modele są dostarczane z 4-drożną klapą (dostępne opcje: filtrowanie, czyszczenie, opróżnianie/odpływ, zamknięcie lub zimowanie).

** Pozycje te odnoszą się wyłącznie do klapy 6-drożnej.

CS 6. RECIRCULATION POSITION / CIRCULATION:** Position used so the water circulates through the hydraulic network without passing through the filter. This possibility is used to move the water if you want to add a product to the pool or if you should perform any operation in the filter, because in this case the filter is isolated and the water coming from the pump is directly expelled.

* Some models are delivered with 4-way flap (available options: Filtering, Washing, Emptying/drain Closed or wintering).

** These positions refer exclusively to the 6-way flap.

SK 6. RECIRCULATION POSITION / CIRCULATION:** Position used so the water circulates through the hydraulic network without passing through the filter. This possibility is used to move the water if you want to add a product to the pool or if you should perform any operation in the filter, because in this case the filter is isolated and the water coming from the pump is directly expelled.

* Some models are delivered with 4-way flap (available options: Filtering, Washing, Emptying/drain Closed or wintering).

** These positions refer exclusively to the 6-way flap.

RO 6. POZIȚIA RECIRCULAȚIEI / CIRCULAȚIEI **: Poziția utilizată astfel încât apa să circule prin rețeaua hidraulică fără a trece prin filtru. Această posibilitate este utilizată pentru a muta apa dacă doriți să adăugați un produs la piscină sau dacă ar trebui să efectuați orice operație în filtru, deoarece în acest caz filtrul este izolat și apa provenită din pompă este expulzată direct.

* Unele modele sunt livrate cu clapetă cu 4 căi (opțiuni disponibile: filtrare, spălare, golire / golire închis sau iernat).

** Aceste poziții se referă exclusiv la clapeta cu 6 căi.

SV 6. ÅTERSTÄLLNINGSPÖSITION / CIRKULATION:** Position som används så att vattnet cirkulerar genom det hydrauliska nätverket utan att passera genom filtret. Denna möjlighet används för att flytta vattnet om du vill lägga till en produkt i poolen eller om du skulle utföra någon åtgärd i filtret, för i det här fallet är filtret isolerat och vattnet som kommer från pumpen utmatas direkt.

* Vissa modeller levereras med 4-vägs klaff (tillgängliga alternativ: Filtrering, tvätt, tömning / tömning Stängd eller övervintring).

** Dessa positioner avser endast 6-vägsklaffar.

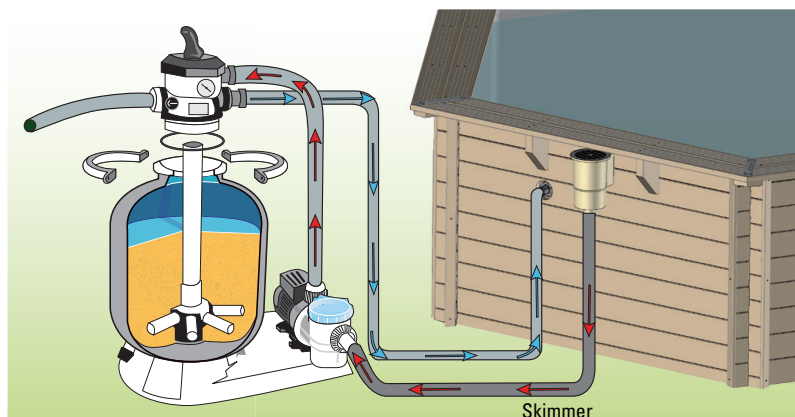
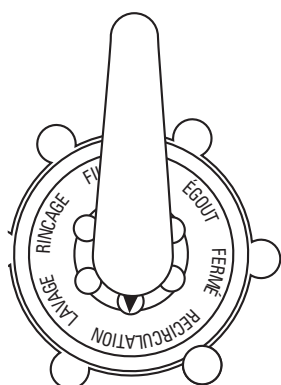

- ⚠ You should never manoeuvre the multi-directional flap when the pump is working.
- ⚠ Nigdy nie wolno manewrować klapy wielokierunkową, gdy pompa pracuje.
- ⚠ La vanne multivoies ne devra jamais être manoeuvrée lorsque la pompe est en marche.
- ⚠ Die mehrrichtungsklappe darf nie bedient werden, wenn die Pumpe läuft.
- ⚠ Non si deve mai maneggiare lo sportello multidirezionale mentre la pompa è in funzione.
- ⚠ Nu trebuie să manevrați niciodată clapeta multidirecțională atunci când pompa funcționează.
- ⚠ Du bör aldrig manövrera flervägsklaffen när pumpen fungerar.



5

- EN MAINTENANCE AND USE
- PL KONSERWACJA I UŻYTKOWANIE
- CS MAINTENANCE AND USE
- SK MAINTENANCE AND USE
- RO ÎNTREȚINERE ȘI UTILIZARE
- SV UNDERHÅLL OCH ANVÄNDNING

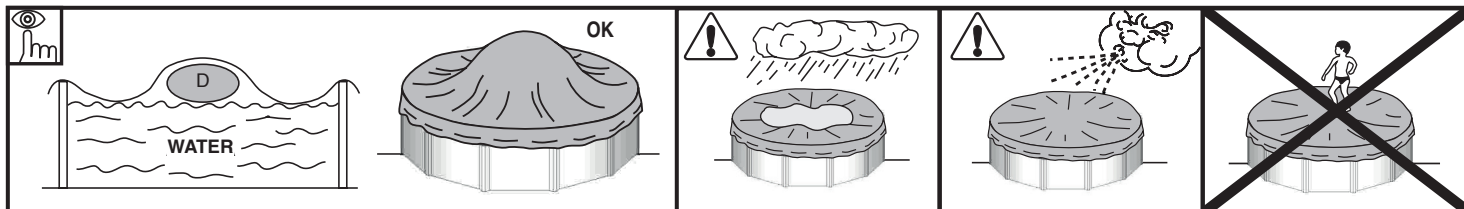

EN RESPECT THE ENVIRONMENT DO NOT TAKE APART THE POOL UNLESS IT IS STRICTLY NECESSARY. IF YOU DO SO, PLEASE REUSE THE WATER. WATER IS A SCARCE GOOD

When your pool reaches the end of its useful life, it should be disassembled; the different materials (plastic and steel) should be separated and taken to the disposal point indicated by local authorities.

MAINTENANCE AND USE:

- Switch on the filter system once a day in to insure a complete water volume renewal and never do it when somebody is in the pool (see filter manual).
- Check the filter's level of clogging regularly in summer when the pool kit is in use.
- Check screws, nuts and washers (for rust).
- The pool water level has always to be hold in a minimum of 15 cm from the pool superior edge.
- Never empty the pool completely. Low water levels may cause serious damage to the pool.
- Failure to comply with the maintenance instructions may lead to serious health risks, especially for children.
- The use of a swimming costume entails respect for the safety regulations set out in the maintenance and user guide.
- Never leave a pool kit empty on the ground, outdoors.
- Clean regularly the P.V.C liner and the water level mark with non-abrasive products. Regularly clean the fold joining the bottom to the side of the liner, as it is an area where dirt accumulates. If you do by accident a small hole in the liner, you can repair it thanks to our rubber patches AR202 or V12.
- The isothermic covers (for the summer) protect your pool from insects, dust, leaves,... and avoid to loose the water temperature. Do always set it in order the bubbles are in contact with the water.

WINTER-SEASON:

A) IF YOU CHOOSE NOT TO DISMOUNT THE POOL:

- 1- Clean the liner bottom and sides with a non-abrasive product.
 - 2- Treat the water with a chemical product for wintering. We recommend using LIQUID WINTERISER instead of floats with solid product to avoid discolouring the liner.
 - 3- Leave the pool full of water considering:
 - a) For pools with skimmer and refilling pipe, reduce the water level 5 cm underneath the skimmer and close the refilling pipe with the screw tap which is included with the filter.
 - b) For pools with exhaustion and refilling pipes, reduce the water level 20 cm from the superior edge of the pool and close the pipes using the screw system incorporated.
 - 4- Disconnect the pipes. Do not dismantle the skimmer and the refilling and exhaustion pipes.
 - 5- Protect the pool with a winter cover, and put a floating element between the cover and the water, in order to protect it from frost.
 - 6- Filter: disconnect it from the pool. Clean it, empty the sand or remove the cartridge, dry it and keep it in a covered and sheltered from dampness place.
 - 7- Accessories: remove every accessories (ladder, alarm, spotlight, pole...), rinse them with soft water and tidy them away.
- TO RUN THE POOL AGAIN: Remove the winter cover, install the filter, change at least 1/3 of water and realize a chlorine treatment. Switch on the filter for at least 8 hours in an uninterrupted way, respecting the continuous working period indicated in the filter manuals.

B) IF YOU CHOOSE TO DISMOUNT THE POOL:

- 1- Empty the pool. Measures: Filter, Automatic pump for handling clean water or communicating vessels system. Communicating vessels system: Use the hose from your filter with the smallest cross-section. Fix a weight to one of its end and plunge it into the swimming pool. After this, sink the whole hose, until there is no air inside. With one hand, and under the water stop up hermetically the end of the hose and take it to the emptying point. Remove hand, and water will start running. Do not use this water for watering the plants, because it contains chemical products.
 - 2- Clean every pool constituents with a sponge and a soap product with a neutral pH. Dry them and tidy them away in a dry and clean place. That's normal that after having installed and dismantled the pool several times, the P.V.C liner dilate and loose its elasticity.
- TO RUN THE POOL AGAIN: Read another time this manual instructions from the beginning..

CHIMICAL MEASURES:

Please read carefully the chemical product manufacturer instructions. WARNING: Keep chemical products in a clean, dry and out of children place. Important: Every products used have to be compatible with the P.V.C liner.

- First filling: Analyse the water pH and chlorine (Cl) and adjust them to the optimal levels: pH: 7,2 – 7,6; Chlorine: 0.5 – 2 ppm.
- Chlorine treatments: Consist in increasing the chlorine level until approximatively 20 ppm to eliminate germs and seaweeds. This process has to be done only when the pool water comes from rivers or ponds, ... or if it stayed a long time without any treatments.
- Checking: Check at least once a week the chlorine levels (use a chlorine and pH analyser). In the same way, we advise to add an algicide to prevent seaweeds appearance. Never have a swim before the chlorine level stabilization. Do always use a floating dispenser for the chemical product (tablets) dissolution. The chemical product measuring out has to be done in accordance with: Your pool water volume, the bathe frequency, the climatic conditions, the water temperature and the location. Do always move the water and wait for the chemical product dissolution before adding another one. Wait approximatively 12 hours between any pH, chlorine or algicide adjustment using the filter system.

MECHANICAL MEASURES:

Check the filter, the skimmer, the valves and the pipes are well connected to the pool. Do consider high water temperature will involved more time for the filtering. Theoretic filtering time = Water volume / Filter system discharge (generally 8h/day with water temperature of 21°C), (Ideal: 2h in the morning – 4h around midday – 2h in the afternoon). **PLEASE RESPECT THE CONTINUOUS WORKING PERIOD INDICATED IN THE FILTER MANUALS.**

VACUUM CLEANER (MANUAL OR AUTOMATIC):

Only for pools with skimmer. Connect an hose extremity to the brush head and immerse it into the water to make it fill in. Connect the other pipe extremity to the exhaustion adapter (TA) and place it above the skimmer basket. Switch on the filter in the FILTER position and begin to clean the bottom. Pay special attention to areas with folds where dirt accumulates.

BOTTOM CLEANER VENTURY STYLE:

Connect a garden hose to the bottom cleaner join and introduce it into the pool. Open the tap until a normal pressure to make the water flow out against the bottom of the pool, producing in that way an ascendant stream which leave the dirt into the filter (bag) which is adjust on the bottom cleaner.

| PROBLEM | CAUSE | SOLUTION |
|---------------------------------------|---|--|
| Muddy water | Bad filtration. High PH. Organic residues in excess | Backwash the filter. Add CLARIFYING agent in tablet form in a dispenser. Carry out a shock chlorination. |
| Green water | Seaweed or mud formation | Gently brush the bottom and walls of the pool. Test pH and adjust to between 7.2-7.6. Add ALGICIDE and LIQUID CLARIFIER. |
| Brown water | Presence of iron or manganese | Test pH and adjust to between 7.2-7.6. Perform SHOCK CHLORINATION. Add LIQUID CLEANER. |
| Incustrations | Presence of Calcareous in the water | Test pH and adjust to between 7.2-7.6. Add ANTI CHALCARE once a week. |
| Eyes and skin irritations. Bad smell. | Misadjusted PH. Organic residues in excess | Test pH and adjust to between 7.2-7.6. Perform a SHOCK CHLORINATION. |

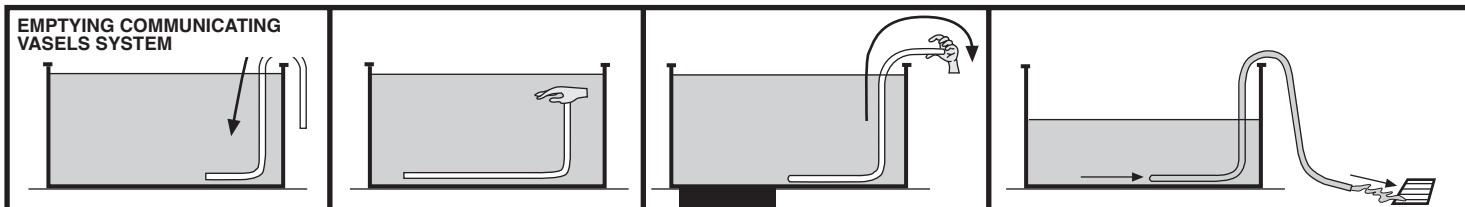

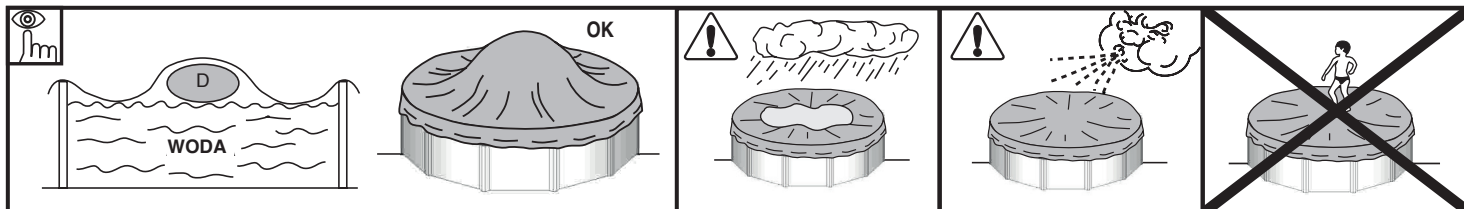

**PL SZANUJ ŚRODOWISKO
NIE NALEŻY DEMONTOWAĆ BASENU, CHYBA ŻE JEST TO ABSOLUTNIE KONIECZNE. JEŚLI TO ZROBISZ, PAMIĘTAJ O PONOWNYM WYKORZYSTANIU WODY. WODA JEST ZASOBEM DEFICYTOWYM**

W momencie, gdy Twój basen nie będzie nadawał się do dalszego użytku, należy go zdemontować, a poszczególne materiały (plastik i stal) należy posegregować i przekazać do punktu utylizacji wskazanego przez lokalne władze.

KONSERWACJA I UŻYTKOWANIE:

- System filtracyjny należy włączać raz dziennie w celu przefiltrowania całości wody i nigdy nie wolno robić tego, gdy ktoś kąpie się w basenie (patrz instrukcja obsługi filtra).
- Regularnie sprawdzaj stopień zabrudzenia filtra w lecie, gdy basen jest używany.
- Sprawdzaj śruby, nakrętki i podkładki, czy nie powstaje na nich rdza.
- Poziom wody w basenie musi być zawsze utrzymywany w odległości minimum 15 cm od górnej krawędzi basenu.
- Nigdy nie należy całkowicie opróżniać basenu. Niski poziom wody może doprowadzić do poważnego uszkodzenia basenu.
- Nieprzestrzeganie instrukcji konserwacji może prowadzić do poważnych zagrożeń dla zdrowia, zwłaszcza dzieci.
- Używanie stroju kąpielowego również wiąże się z przestrzeganiem zasad bezpieczeństwa określonych w instrukcji konserwacji i użytkowania.
- Nigdy nie należy pozostawiać pustego basenu na ziemi, gdy znajduje się on na zewnątrz.
- Należy regularnie czyścić liner P.V.C i ślad po wodzie za pomocą środków nieściernych. Regularnie czyść fałdę łączącą dno z bokiem wkładu basenowego, ponieważ jest to obszar, w którym gromadzi się brud. Jeśli przez przypadek zrobisz małą dziurę w linerze, możesz ją naprawić dzięki naszym gumowym łatkom AR202 lub V12.
- Osłony izotermiczne (na lato) chronią basen przed owadami, kurzem, liśćmi itd. i pomagają w utrzymaniu stałej temperatury wody. Osłonę należy nałożyć na basen w taki sposób, aby pęcherzyki powietrza miały kontakt z wodą.

SEZON ZIMOWY:

A) JEŚLI NIE ZDECYDUJESZ SIĘ NA DEMONTAŻ BASENU:

- 1- Wyczyść dno i boki lineru środkiem nieściernym.
- 2- Zastosuj specjalne środki do przygotowania basenu na zimę. Zalecamy użycie PŁYNNEGO ŚRODKA DO ZIMOWANIA BASENU zamiast płynów z produktem stałym, aby zapobiec odparzeniu wkładu basenowego.
- 3- Nie należy spuszczać wody z basenu, biorąc pod uwagę następujące sytuacje:
 - a) W przypadku basenów ze skimmerem i rurą do napełniania, należy obniżyć poziom wody do 5 cm poniżej skimmera i zamknąć rurę do napełniania basenu za pomocą gwintowanego zaworu odcinającego dołączonego do filtra.
 - b) W przypadku basenów z rurą do spuszczenia i napełniania wody, obniż poziom wody do 20 cm od górnej krawędzi basenu i zakręć rury za pomocą wbudowanych gwintowanych rur odcinających.
- 4- Odkręć rury. Nie należy demontować skimmera ani rur do napełniania i odprowadzania wody.
- 5- Zabezpiecz basen za pomocą osłony zimowej i umieść element, który będzie się unosił pomiędzy osłoną a powierzchnią wody, aby chronić ją przed mrozem.
- 6- Odłącz filtr od basenu. Wyczyść go, opróżnij z piasku lub wyjmij wkład, a następnie wysusz i przechowuj w zadaszkonym i chronionym przed wilgocią miejscu.
- 7- Akcesoria: zdemontuj wszystkie akcesoria (drabinkę, alarm, reflektor, kolumnę itd.), opłucz je miękką wodą i schowaj.

ABY PONOWNIE URUCHOMIĆ BASEN, NALEŻY: Zdjąć osłonę zimową, zainstalować filtr, wymienić co najmniej 1/3 wody i przeprowadzić chlorowanie. Następnie należy włączyć filtr na co najmniej 8 godzin, w sposób nieprzerwany, biorąc pod uwagę okres ciągłej pracy urządzenia wskazany w instrukcji obsługi filtra.

B) JEŚLI ZDECYDUJESZ SIĘ NA DEMONTAŻ BASENU:

- 1- Opróżnij basen. Środki: Filtr, automatyczna pompa do podawania czystej wody lub system połączonych zbiorników. System połączonych zbiorników: Użyj węża o najmniejszym przekroju i zamontuj go do filtra. Do jednego z jego końców przymocuj obciążnik i zanurz go w basenie. Następnie zanurz cały wąż, aż w środku nie będzie powietrza. Jedną ręką, pod wodą, zatkaj hermetycznie koniec węża i przenieś go do miejsca odpływu wody. Usuń rękę, a woda zacznie płynąć. Nie używaj tej wody do podlewania roślin, ponieważ zawiera ona środki chemiczne.
 - 2- Wyczyść wszystkie elementy basenu za pomocą gąbki i mydła o neutralnym pH. Wysusz je i schowaj w suchym i czystym miejscu. Normalne jest, że po kilkukrotnym montażu i demontażu basenu, wykładzina P.V.C rozchodzi się i traci swoją elastyczność.
- ABY PONOWNIE URUCHOMIĆ BASEN, NALEŻY: Przeczytać jeszcze raz niniejszą instrukcję obsługi od początku.

ŚRODKI CHEMICZNE:

Należy dokładnie zapoznać się z instrukcją producenta środka chemicznego. UWAGA: Produkty chemiczne należy przechowywać w czystym, suchym i niedostępnym dla dzieci miejscu. Ważne: Wszystkie stosowane produkty muszą być kompatybilne z wkładem P.V.C.

- Pierwsze napełnienie: Sprawdź poziom pH wody oraz chloru (Cl) i dostosuj je do optymalnych poziomów: pH: 7,2 - 7,6; Chlor: 0,5 - 2 ppm.
- Chlorowanie: Zwiększ poziom chloru do około 20 ppm, aby wyeliminować zaskaki i glony. Proces ten musi zostać przeprowadzony tylko wtedy, gdy woda w basenie pochodzi z rzek lub stawów, lub w momencie, gdy nie stosowano środków chemicznych przez długi okres czasu.
- Sprawdzanie: Przynajmniej raz w tygodniu sprawdzaj poziom chloru (użyj analizatora chloru i poziomu pH). Zalecamy również dodawać do wody środek algobójczy, aby zapobiec powstawaniu glonów. Nigdy nie kąp się przed ustabilizowaniem się poziomu chloru. Należy używać płynającego dozownika do rozpuszczenia produktu chemicznego (tabletek). Dawka produktów chemicznych musi być zgodna z: objętością wody w Twoim basenie, częstotliwością kąpieli, warunkami klimatycznymi, temperaturą wody i miejscem. Zawsze należy wymieszać wodę i poczekać na rozpuszczenie się środka chemicznego przed dodaniem kolejnego. Odczekaj ok. 12 godzin przed dodaniem jakichkolwiek środków poprawiających pH, chloru lub algicydów za pomocą systemu filtracyjnego.

ŚRODKI MECHANICZNE:

Sprawdź, czy filtr, skimmer, zawory i rury są odpowiednio podłączone do basenu. Należy pamiętać, że przy wysokiej temperaturze wody wymagany jest dłuższy czas filtrowania. Teoretyczny czas filtracji = objętość wody / moc filtra (generalnie 8h dziennie przy temperaturze wody 21°C), (Idealnie: 2h rano - 4h około południa - 2h po południu). **NALEŻY UWZGLĘDNIĆ CIĄGŁOŚĆ PRACY PODANĄ W INSTRUKCJI OBSŁUGI FILTRA.**

ODKURZACZ (RĘCZNY LUB AUTOMATYCZNY):

Tylko dla basenów ze skimmerem. Podłącz końcówkę węża do głowicy szczotki i zanurz ją w wodzie, aby się napełniła. Podłącz drugi koniec węża do adaptera wyciągu (TA) i umieść go nad koszykiem skimmera. Włącz filtr w pozycji FILTROWANIE i rozpocznij czyszczenie dna. Zwróć szczególną uwagę na miejsca z zagłębieniami, gdzie gromadzi się brud.

URZĄDZENIE DO CZYSZCZENIA DNA TYPU „VENTURY STYLE”:

Podłącz wąż ogrodowy do złącza czyszczącego dna i zanurz go w wodzie. Otwórz kran, aż do uzyskania normalnego poziomu ciśnienia, aby powstał strumień pod wodą, który spowoduje, że zanieczyszczenia zostaną uniesione do filtra (woreczka), który znajduje się na urządzeniu do czyszczenia dna.

| PROBLEM | PRZYCZYNA | ROZWIĄZANIE |
|---|---|--|
| Mętna woda | Nieodpowiednia filtracja. Wysoki poziom PH. Nadmiar masy organicznej. | Przepłucz filtr. Dodaj środek CZYSZCZĄCY w tabletkach do dozownika. Przeprowadzić chlorowanie wstrząsowe. |
| Zielona woda | Tworzenie się glonów lub błota | Delikatnie wyszczotkuj dno i ściany basenu. Sprawdź poziom pH i wyreguluj do wartości pomiędzy 7,2-7,6. Dodaj ŚRODEK GLONOBÓJCZY i KOAGULANT W PŁYNIĘ. |
| Brązowa woda | Obecność żelaza lub manganu | Sprawdź poziom pH i wyreguluj do wartości pomiędzy 7,2-7,6. Przeprowadź CHLOROWANIE WSTRZĄSOWE. Dodaj PŁYN DO CZYSZCZENIA BASENÓW. |
| Inkrustacje | Obecność wapnia w wodzie | Sprawdź poziom pH i wyreguluj do wartości pomiędzy 7,2-7,6. Dodaj ŚRODEK OKAMIAJĄCY raz w tygodniu. |
| Podrażnienia oczu i skóry. Nieprzyjemny zapach. | Niewłaściwy poziom PH. Nadmiar masy organicznej. | Sprawdź poziom pH i wyreguluj do wartości pomiędzy 7,2-7,6. Przeprowadź CHLOROWANIE WSTRZĄSOWE. |

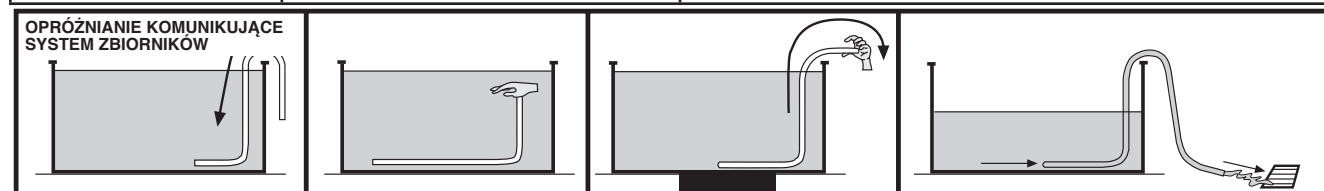

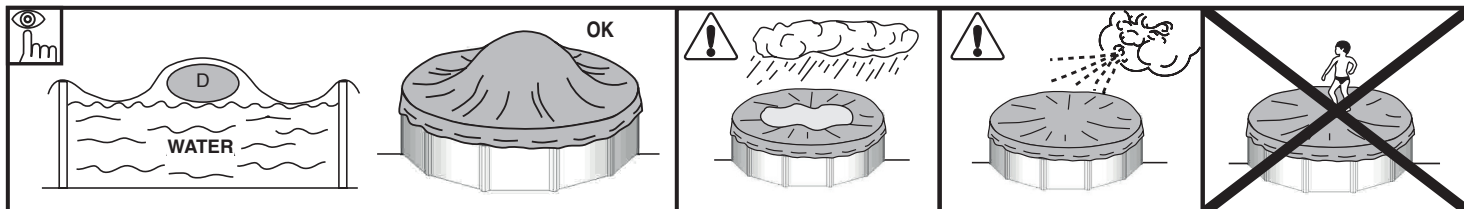

CS RESPECT THE ENVIRONMENT
DO NOT TAKE APART THE POOL UNLESS IT IS STRICTLY NECESSARY. IF YOU DO SO, PLEASE REUSE THE WATER. WATER IS A SCARCE GOOD

When your pool reaches the end of its useful life, it should be disassembled; the different materials (plastic and steel) should be separated and taken to the disposal point indicated by local authorities.

MAINTENANCE AND USE:

- Switch on the filter system once a day in to insure a complete water volume renewal and never do it when somebody is in the pool (see filter manual).
- Check the filter's level of clogging regularly in summer when the pool kit is in use.
- Check screws, nuts and washers (for rust).
- The pool water level has always to be hold in a minimum of 15 cm from the pool superior edge.
- Never empty the pool completely. Low water levels may cause serious damage to the pool.
- Failure to comply with the maintenance instructions may lead to serious health risks, especially for children.
- The use of a swimming costume entails respect for the safety regulations set out in the maintenance and user guide.
- Never leave a pool kit empty on the ground, outdoors.
- Clean regularly the P.V.C liner and the water level mark with non-abrasive products. Regularly clean the fold joining the bottom to the side of the liner, as it is an area where dirt accumulates. If you do by accident a small hole in the liner, you can repair it thanks to our rubber patches AR202 or V12.
- The isothermic covers (for the summer) protect your pool from insects, dust, leaves,... and avoid to loose the water temperature. Do always set it in order the bubbles are in contact with the water.

WINTER-SEASON:

A) IF YOU CHOOSE NOT TO DISMOUNT THE POOL:

- 1- Clean the liner bottom and sides with a non-abrasive product.
 - 2- Treat the water with a chemical product for wintering. We recommend using LIQUID WINTERISER instead of floats with solid product to avoid discolouring the liner.
 - 3- Leave the pool full of water considering:
 - a) For pools with skimmer and refilling pipe, reduce the water level 5 cm underneath the skimmer and close the refilling pipe with the screw tap which is included with the filter.
 - b) For pools with exhaustion and refilling pipes, reduce the water level 20 cm from the superior edge of the pool and close the pipes using the screw system incorporated.
 - 4- Disconnect the pipes. Do not dismantle the skimmer and the refilling and exhaustion pipes.
 - 5- Protect the pool with a winter cover, and put a floating element between the cover and the water, in order to protect it from frost.
 - 6- Filter: disconnect it from the pool. Clean it, empty the sand or remove the cartridge, dry it and keep it in a covered and sheltered from dampness place.
 - 7- Accessories: remove every accessories (ladder, alarm, spotlight, pole...), rinse them with soft water and tidy them away.
- TO RUN THE POOL AGAIN: Remove the winter cover, install the filter, change at least 1/3 of water and realize a chlorine treatment. Switch on the filter for at least 8 hours in an uninterrupted way, respecting the continuous working period indicated in the filter manuals.

B) IF YOU CHOOSE TO DISMOUNT THE POOL:

- 1- Empty the pool. Measures: Filter, Automatic pump for handling clean water or communicating vessels system. Communicating vessels system: Use the hose from your filter with the smallest cross-section. Fix a weight to one of its end and plunge it into the swimming pool. After this, sink the whole hose, until there is no air inside. With one hand, and under the water stop up hermetically the end of the hose and take it to the emptying point. Remove hand, and water will start running. Do not use this water for watering the plants, because it contains chemical products.
 - 2- Clean every pool constituents with a sponge and a soap product with a neutral pH. Dry them and tidy them away in a dry and clean place. That's normal that after having installed and dismantled the pool several times, the P.V.C liner dilate and loose its elasticity.
- TO RUN THE POOL AGAIN: Read another time this manual instructions from the beginning..

CHEMICAL MEASURES:

Please read carefully the chemical product manufacturer instructions. WARNING: Keep chemical products in a clean, dry and out of children place. Important: Every products used have to be compatible with the P.V.C liner.

- First filling: Analyse the water pH and chlorine (Cl) and adjust them to the optimal levels: pH: 7,2 - 7,6; Chlorine: 0.5 - 2 ppm.
- Chlorine treatments: Consist in increasing the chlorine level until approximatively 20 ppm to eliminate germs and seaweeds. This process has to be done only when the pool water comes from rivers or ponds, ... or if it stayed a long time without any treatments.
- Checking: Check at least once a week the chlorine levels (use a chlorine and pH analyser). In the same way, we advise to add an algicide to prevent seaweeds appearance. Never have a swim before the chlorine level stabilization. Do always use a floating dispenser for the chemical product (tablets) dissolution. The chemical product measuring out has to be done in accordance with: Your pool water volume, the bathe frequency, the climatic conditions, the water temperature and the location. Do always move the water and wait for the chemical product dissolution before adding another one. Wait approximatively 12 hours between any pH, chlorine or algicide adjustment using the filter system.

MECHANICAL MEASURES:

Check the filter, the skimmer, the valves and the pipes are well connected to the pool. Do consider high water temperature will involved more time for the filtering. Theoretic filtering time = Water volume / Filter system discharge (generally 8h/day with water temperature of 21°C), (Ideal: 2h in the morning - 4h around midday - 2h in the afternoon). **PLEASE RESPECT THE CONTINUOUS WORKING PERIOD INDICATED IN THE FILTER MANUALS.**

VACUUM CLEANER (MANUAL OR AUTOMATIC):

Only for pools with skimmer. Connect an hose extremity to the brush head and immerse it into the water to make it fill in. Connect the other pipe extremity to the exhaustion adapter (TA) and place it above the skimmer basket. Switch on the filter in the FILTER position and begin to clean the bottom. Pay special attention to areas with folds where dirt accumulates.

BOTTOM CLEANER VENTURY STYLE:

Connect a garden hose to the bottom cleaner join and introduce it into the pool. Open the tap until a normal pressure to make the water flow out against the bottom of the pool, producing in that way an ascendant stream which leave the dirt into the filter (bag) which is adjust on the bottom cleaner.

| PROBLEM | CAUSE | SOLUTION |
|--|---|--|
| Muddy water | Bad filtration. High PH. Organic residues in excess | Backwash the filter. Add CLARIFYING agent in tablet form in a dispenser. Carry out a shock chlorination. |
| Green water | Seaweed or mud formation | Gently brush the bottom and walls of the pool. Test pH and adjust to between 7.2-7.6. Add ALGICIDE and LIQUID CLARIFIER. |
| Brown water | Presence of iron or manganese | Test pH and adjust to between 7.2-7.6. Perform SHOCK CHLORINATION. Add LIQUID CLEANER. |
| Incustrations | Presence of Calcareous in the water | Test pH and adjust to between 7.2-7.6. Add ANTI CHALCARE once a week. |
| IEyes and skin irritations. Bad smell. | Misadjusted PH. Organic residues in excess | Test pH and adjust to between 7.2-7.6. Perform a SHOCK CHLORINATION. |

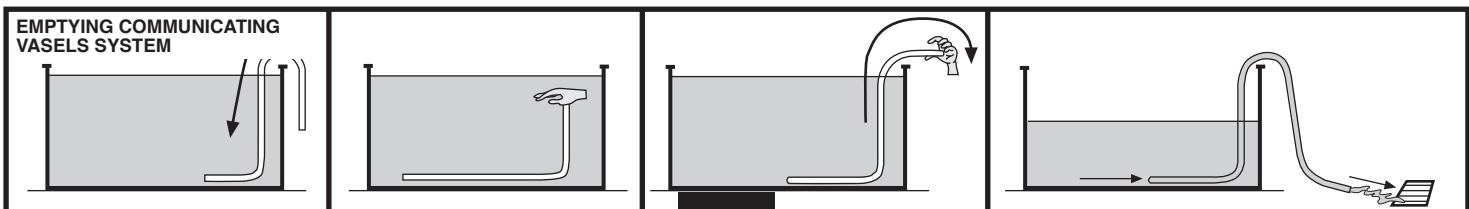

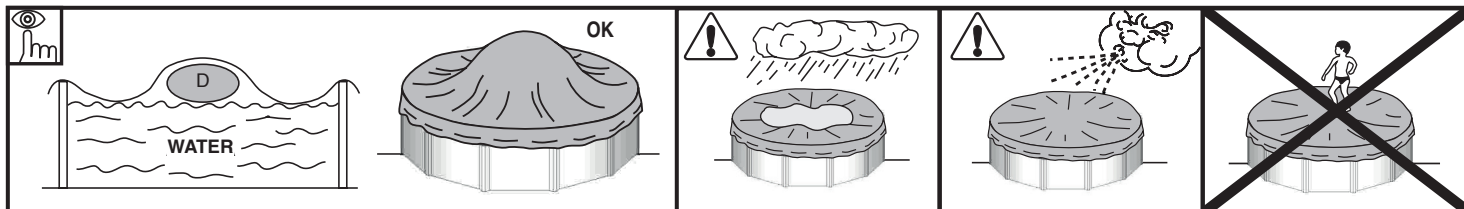

SK RESPECT THE ENVIRONMENT DO NOT TAKE APART THE POOL UNLESS IT IS STRICTLY NECESSARY. IF YOU DO SO, PLEASE REUSE THE WATER. WATER IS A SCARCE GOOD

When your pool reaches the end of its useful life, it should be disassembled; the different materials (plastic and steel) should be separated and taken to the disposal point indicated by local authorities.

MAINTENANCE AND USE:

- Switch on the filter system once a day in to insure a complete water volume renewal and never do it when somebody is in the pool (see filter manual).
- Check the filter's level of clogging regularly in summer when the pool kit is in use.
- Check screws, nuts and washers (for rust).
- The pool water level has always to be hold in a minimum of 15 cm from the pool superior edge.
- Never empty the pool completely. Low water levels may cause serious damage to the pool.
- Failure to comply with the maintenance instructions may lead to serious health risks, especially for children.
- The use of a swimming costume entails respect for the safety regulations set out in the maintenance and user guide.
- Never leave a pool kit empty on the ground, outdoors.
- Clean regularly the P.V.C liner and the water level mark with non-abrasive products. Regularly clean the fold joining the bottom to the side of the liner, as it is an area where dirt accumulates. If you do by accident a small hole in the liner, you can repair it thanks to our rubber patches AR202 or V12.
- The isothermic covers (for the summer) protect your pool from insects, dust, leaves,... and avoid to loose the water temperature. Do always set it in order the bubbles are in contact with the water.

WINTER-SEASON:

A) IF YOU CHOOSE NOT TO DISMOUNT THE POOL:

- 1- Clean the liner bottom and sides with a non-abrasive product.
 - 2- Treat the water with a chemical product for wintering. We recommend using LIQUID WINTERISER instead of floats with solid product to avoid discolouring the liner.
 - 3- Leave the pool full of water considering:
 - a) For pools with skimmer and refilling pipe, reduce the water level 5 cm underneath the skimmer and close the refilling pipe with the screw tap which is included with the filter.
 - b) For pools with exhaustion and refilling pipes, reduce the water level 20 cm from the superior edge of the pool and close the pipes using the screw system incorporated.
 - 4- Disconnect the pipes. Do not dismantle the skimmer and the refilling and exhaustion pipes.
 - 5- Protect the pool with a winter cover, and put a floating element between the cover and the water, in order to protect it from frost.
 - 6- Filter: disconnect it from the pool. Clean it, empty the sand or remove the cartridge, dry it and keep it in a covered and sheltered from dampness place.
 - 7- Accessories: remove every accessories (ladder, alarm, spotlight, pole...), rinse them with soft water and tidy them away.
- TO RUN THE POOL AGAIN: Remove the winter cover, install the filter, change at least 1/3 of water and realize a chlorine treatment. Switch on the filter for at least 8 hours in an uninterrupted way, respecting the continuous working period indicated in the filter manuals.

B) IF YOU CHOOSE TO DISMOUNT THE POOL:

- 1- Empty the pool. Measures: Filter, Automatic pump for handling clean water or communicating vessels system. Communicating vessels system: Use the hose from your filter with the smallest cross-section. Fix a weight to one of its end and plunge it into the swimming pool. After this, sink the whole hose, until there is no air inside. With one hand, and under the water stop up hermetically the end of the hose and take it to the emptying point. Remove hand, and water will start running. Do not use this water for watering the plants, because it contains chemical products.
 - 2- Clean every pool constituents with a sponge and a soap product with a neutral pH. Dry them and tidy them away in a dry and clean place. That's normal that after having installed and dismantled the pool several times, the P.V.C liner dilate and loose its elasticity.
- TO RUN THE POOL AGAIN: Read another time this manual instructions from the beginning..

CHIMICAL MEASURES:

Please read carefully the chemical product manufacturer instructions. WARNING: Keep chemical products in a clean, dry and out of children place. Important: Every products used have to be compatible with the P.V.C liner.

- First filling: Analyse the water pH and chlorine (Cl) and adjust them to the optimal levels: pH: 7,2 - 7,6; Chlorine: 0.5 - 2 ppm.
- Chlorine treatments: Consist in increasing the chlorine level until approximatively 20 ppm to eliminate germs and seaweeds. This process has to be done only when the pool water comes from rivers or ponds, ... or if it stayed a long time without any treatments.
- Checking: Check at least once a week the chlorine levels (use a chlorine and pH analyser). In the same way, we advise to add an algicide to prevent seaweeds appearance. Never have a swim before the chlorine level stabilization. Do always use a floating dispenser for the chemical product (tablets) dissolution. The chemical product measuring out has to be done in accordance with: Your pool water volume, the bathe frequency, the climatic conditions, the water temperature and the location. Do always move the water and wait for the chemical product dissolution before adding another one. Wait approximatively 12 hours between any pH, chlorine or algicide adjustment using the filter system.

MECHANICAL MEASURES:

Check the filter, the skimmer, the valves and the pipes are well connected to the pool. Do consider high water temperature will involved more time for the filtering. Theoretic filtering time = Water volume / Filter system discharge (generally 8h/day with water temperature of 21°C), (Ideal: 2h in the morning - 4h around midday - 2h in the afternoon). PLEASE RESPECT THE CONTINUOUS WORKING PERIOD INDICATED IN THE FILTER MANUALS.

VACUUM CLEANER (MANUAL OR AUTOMATIC):

Only for pools with skimmer. Connect an hose extremity to the brush head and immerse it into the water to make it fill in. Connect the other pipe extremity to the exhaustion adapter (TA) and place it above the skimmer basket. Switch on the filter in the FILTER position and begin to clean the bottom. Pay special attention to areas with folds where dirt accumulates.

BOTTOM CLEANER VENTURY STYLE:

Connect a garden hose to the bottom cleaner join and introduce it into the pool. Open the tap until a normal pressure to make the water flow out against the bottom of the pool, producing in that way an ascendant stream which leave the dirt into the filter (bag) which is adjust on the bottom cleaner.

| PROBLEM | CAUSE | SOLUTION |
|--|---|--|
| Muddy water | Bad filtration. High PH. Organic residues in excess | Backwash the filter. Add CLARIFYING agent in tablet form in a dispenser. Carry out a shock chlorination. |
| Green water | Seaweed or mud formation | Gently brush the bottom and walls of the pool. Test pH and adjust to between 7.2-7.6. Add ALGICIDE and LIQUID CLARIFIER. |
| Brown water | Presence of iron or manganese | Test pH and adjust to between 7.2-7.6. Perform SHOCK CHLORINATION. Add LIQUID CLEANER. |
| Incustrations | Presence of Calcareous in the water | Test pH and adjust to between 7.2-7.6. Add ANTI CHALCARE once a week. |
| IEyes and skin irritations. Bad smell. | Misadjusted PH. Organic residues in excess | Test pH and adjust to between 7.2-7.6. Perform a SHOCK CHLORINATION. |

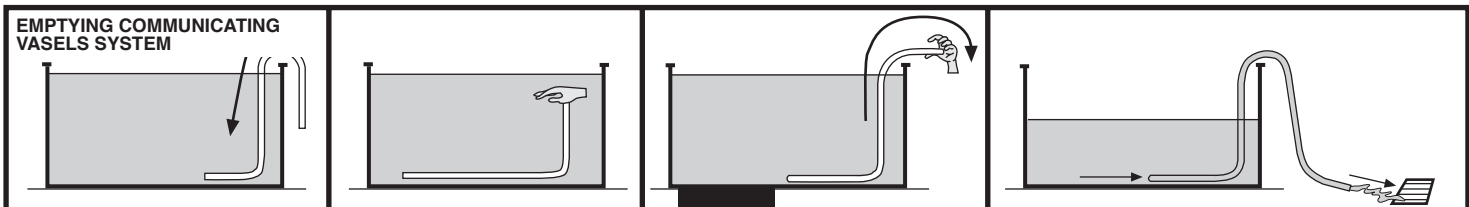

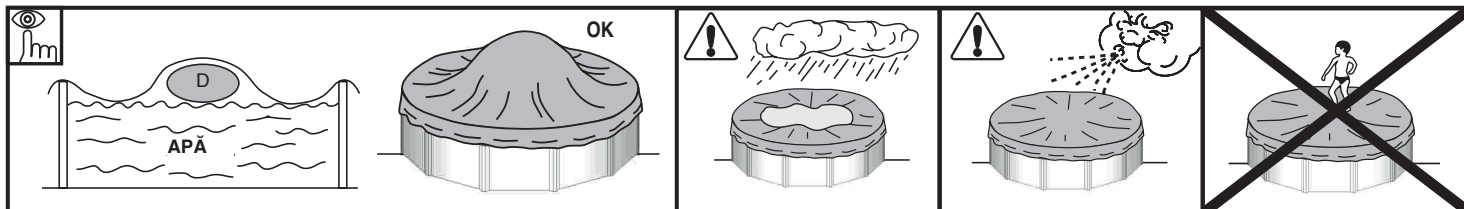

**RO RESPECTAȚI MEDIUL
NU GOLIȚI PISCINA, DOAR DACĂ ESTE STRICT NECESAR. DACĂ O FACEȚI, REUTILIZAȚI APA. APA ESTE BUN PREȚIOS.**

Când piscina dvs. ajunge la sfârșitul vieții sale utile, aceasta ar trebui dezasamblată; diferitele materiale (plastic și oțel) trebuie separate și duse la punctul de eliminare indicat de autoritățile locale.

ÎNȚEȚINERE ȘI UTILIZARE:

- Porniți sistemul de filtrare o dată pe zi pentru a asigura o reînnoire completă a volumului de apă și nu o faceți niciodată când cineva se află în piscină (consultați manualul filtrului).
- Verificați cu regularitate nivelul titrării în timpul verii, atunci când setul de piscină este utilizat.
- Verificați șuruburile, piulițele și șaibe (pentru rugină).
- Nivelul apei piscinei trebuie să fie întotdeauna menținut la minimum 15 cm de la marginea superioară a piscinei.
- Nu goliți niciodată piscina complet. Nivelurile cu apă scăzută pot provoca daune grave piscinei.
- Neconformarea cu instrucțiunile de întreținere poate duce la riscuri crescute pentru sănătate, în special pentru copii.
- Utilizarea unui costum de înot implică respectarea reglementărilor de siguranță stabilite în ghidul de întreținere și de utilizare.
- Nu lăsați niciodată un kit de piscină gol pe sol, în aer liber.
- Curățați în mod regulat căptușeala PVC și marcați nivelulul apei cu produse non-abrazive. Curățați regulat faldul care unește partea inferioară cu partea laterală a căptușelii, deoarece este o zonă în care se acumulează murdărie. Dacă faceți accidental o mică gaură în căptușeală, o puteți repara cu ajutorul patch-urilor noastre de cauciuc AR202 sau V12.
- Capacele izoterme (pentru vară) vă protejează piscina de insecte, praf, frunze, ... și ajută la evitarea pierderii temperaturii apei. Reglați întotdeauna pentru ca bulele să fie în contact cu apa.

SEZONUL DE IARNA:

A) DACĂ ALEGIȚI SĂ NU DEMONTAȚI PISCINA:

- 1- Curățați fundul și părțile laterale ale căptușelii cu un produs neabraziv
- 2- Tratați apa cu un produs chimic pentru iarnă. Vă recomandăm să folosiți LICHID PENTRU IARNĂ în loc de plutitoare cu produs solid pentru a evita decolorarea căptușelii.
- 3- Lăsați piscina plină cu apă luând în considerare:
 - a) Pentru bazinele cu skimmer și țevă de reglare, reduceți nivelul apei cu 5 cm sub skimmer și închideți conducta de reglare cu robinetul cu șurub care este indus cu filtru.
 - b) Pentru bazinele cu țevi de evacuare și reumplere, reduceți nivelul apei la 20 cm de marginea superioară a bazinului și închideți țevile utilizând sistemul de șurub încorporat.
- 4- Deconectați conductele. Nu demontați skimmerul și conductele de reumplere și evacuare.
- 5- Protejați piscina cu un capac de iarnă și puneți un element plutitor în apă, pentru a proteja de îngheț.
- 6- Filtru: deconectați-l de la piscină. Curățați-l, goliți nisipul și scoateți cartușul, uscați-l și păstrați-l într-un loc acoperit și protejat de umezeală.
- 7- Accesorii: îndepărtați toate accesoriile (scară, alarmă, spot, stâlp ...), clățiți-le cu apă moale și ordonați-le.

PENTRU A REFOLOSI PISCINA: Scoateți capacul de iarnă, instalați filtrul, schimbați cel puțin 1/3 din apă și efectuați un tratament cu clor. Porniți filtrul cel puțin 8 ore într-un mod neîntrerupt, respectând perioada de lucru continuă indicată în manualele montatorului.

B) DACĂ ALEGEȚI SĂ DEMONTAȚI PISCINA:

- 1- Goliți piscina. Măsuri: Montator, pompă automată pentru manipularea apei curate sau a sistemelor de nave comunicante. Sistem de nave comunicante: utilizați furtunul de la filtrul cu cea mai mică secțiune transversală. Fixați o greutate la unul dintre capetele sale și plonjați-o în piscină. După asta, scufundați întregul furtun, până când nu există aer în interior. Cu o mână și sub apă opriți ermetic capătul furtunului și duceți-l la punctul de golire. Scoateți mâna și apa va începe să curgă. Nu folosiți această apă pentru udarea plantelor, deoarece conține produse chimice.
- 2- Curățați fiecare componentă a piscinei cu un burete și un produs de săpun cu un pH neutru. Uscați-le și ordonați-le într-un loc uscat și curat. Este normal ca după ce ați instalat și demontat piscina de mai multe ori, căptușeala PVC să se dilate și să își piardă elasticitatea.

PENTRU A REFOLOSI PISCINA: Citiți acest manual de instrucțiuni de la început.

MĂSURI CHIMICE:

Vă rugăm să citiți cu atenție instrucțiunile producătorului de produse chimice. AVERTISMENT: Păstrați produsele chimice într-un loc curat, uscat și nu la îndemâna copiilor. Important Fiecare produs utilizat trebuie să fie compatibil cu căptușeala PVC.

- Prima umplere: Analizați pH-ul apei și clorul (Cl) și reglați-le la nivelurile optime: pH: 7,2 - 7,6; Clor: 0,5 - 2 ppm.
- Tratamente cu clor: constă în creșterea nivelului de clor până la aproximativ 20 ppm pentru a elimina germenii și algele marine. Acest proces trebuie făcut numai atunci când apa din piscină provine din râuri și iazuri ... sau dacă a stat mult timp fără niciun tratament.
- Verificarea Verificați cel puțin o dată pe săptămână nivelurile de clor (utilizați un analizor de clor și pH). În același mod, vă sfătuim să adăugați un algicid pentru a preveni apariția algelor marine. Nu înotați niciodată înainte de stabilizarea nivelului clorului. Utilizați întotdeauna un dozator plutitor pentru dizolvarea produsului chimic (tablete). Măsurarea produsului chimic trebuie făcută în conformitate cu: volumul de apă din piscină, frecvența scaldării, condițiile climatice, temperatura apei și locația. Mutați întotdeauna apa și așteptați dizolvarea produsului chimic înainte de a adăuga alta. Așteptați aproximativ 12 ore între orice ajustare a pH-ului, clorului și a algicidelor folosind sistemul de filtrare.

MĂSURI MECANICE:

Verificați dacă filtrul, skimmerul, supapele și conductele sunt bine conectate la piscină. Luați în considerare că temperatura ridicată a apei va implica mai mult timp pentru filtrare. Timp de filtrare teoretic = Volumul de apă/descărcarea sistemului de filtrare (în general 8h/zi la o temperatură a apei de 21 °C). (Ideal: 2h dimineața -4h în jurul prânzului - 2h după-amiaza). **VĂ RUGĂM SĂ RESPECTAȚI PERIOADA DE LUCRU CONTINUĂ INDICATĂ ÎN MANUALELE DE FILTRARE.**

ASPIRATOR (MANUAL SAU AUTOMAT):

Numai pentru piscine cu skimmer. Conectați o extremitate a furtunului la capul periei și introduceți-o în apă pentru a o umple. Conectați cealaltă extremitate a țevii la adaptorul de evacuare (TA) și așezați-l deasupra coșului skimmer-ului. Porniți filtrul în poziția FILTRARE și începeți să curățați fundul. Acordați o atenție specială zonelor cu pliuiri în care se acumulează murdărie.

CURĂȚĂTORUL DE FUND STILU VENTURY:

Conectați un furtun de grădină la unitatea de curățare inferioară și introduceți-l în piscină. Deschideți robinetul până la o presiune normală pentru a provoca curgerea apei pe fundul piscinei, creând în acest fel un flux ascendent care lasă murdăria în filtrul (sacul) care se reglează pe curățătorul de fund.

| PROBLEMĂ | CAUZĂ | SOLUȚIE |
|---|--|--|
| Apă noroioasă | Filtrare proastă. PH ridicat. Rezi-duuri organice în exces | Realizați o contraspălare a filtrului. Adăugați pastile de CURĂȚARE în dozator. Realizați o clorinare. |
| Apă verzuie | Formarea de alge sau noroi | Curățați ușor fundul și pereții piscinei. Analizați PH-ul și ajustați-l între 7,2-7,6. Adăugați ALGICIDE și SUBSTANȚĂ DE CURĂȚARE LICHIDĂ. |
| Apă maronie | Prezența fierului sau manganului | Analizați PH-ul și ajustați-l între 7,2-7,6. Realizați o CLORINARE. Adăugați SUBSTANȚĂ DE CURĂȚARE LICHIDĂ |
| Incubații | Prezența substanțelor calcaroase în apă | Analizați PH-ul și ajustați-l între 7,2-7,6. Adăugați o dată pe săptămână o substanță ANTO-CALCĂR. |
| Iritarea ochilor și a pielii. Miroas urât | PH prost ajustat. Rezi-duuri organice în exces. | Analizați PH-ul și ajustați-l între 7,2-7,6. Realizați o CLORINARE. |

SISTEM DE VASE COMUNICANTE PENTRU GOLIRE

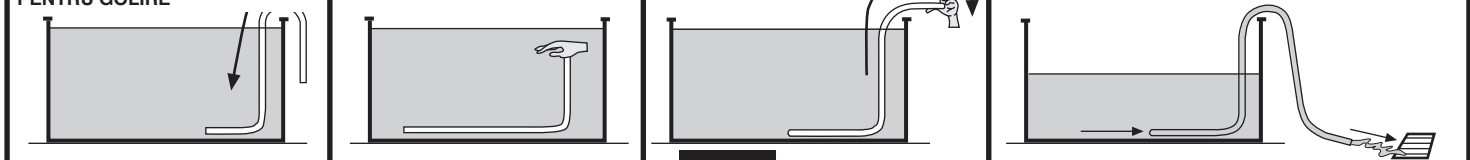

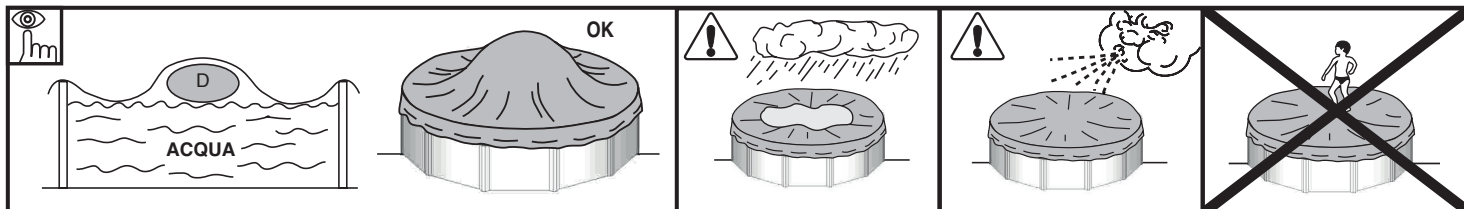

RESPEKTERA MILJÖN

MONTERA INTE NER POOLEN OM DET INTE ÄR NÖDVÄNDIGT. OM DU GÖR SÅ, ÅTERRANVÄND VATTNET. VATTEN ÄR EN SÄLLSYNT

När din pool når slutet av sin livslängd ska den monteras ner. de olika materialen (plast och stål) bör separeras och tas till den avfallshandlingsplats som anges av lokala myndigheter.

UNDERHÅLL OCH ANVÄNDNING:

- Slå på filtersystemet en gång om dagen för att säkerställa en fullständig förnyelse av vattenvolymen och gör det aldrig när någon är i poolen (se filterhandboken).
- Kontrollera filtrets igensättningsnivå regelbundet på sommaren när poolkitten används.
- Kontrollera skruvar, muttrar och brickor (för rost).
- Poolens vattennivå måste alltid hållas minst 15 cm från poolens översta kant.
- Töm aldrig poolen helt. Låga vattennivåer kan orsaka allvarliga skador på poolen.
- Om underhållsanvisningarna inte följs kan det leda till allvarliga hälsorisker, särskilt för barn.
- Användningen av en baddräkt innebär respekt för de säkerhetsbestämmelser som anges i underhålls- och användarhandboken.
- Lämna aldrig ett poolpaket tomt på marken utomhus.
- Rengör regelbundet PVC-linern och vattennivåmarkeringen med icke-slipande produkter. Rengör regelbundet vikningen som förbinder botten med sidan av linern, eftersom det är ett område där smuts ansamlas. Om du av misstag gör ett litet hål i linern kan du reparera det tack vare våra gummipatcher AR202 eller V12.
- De isotermiska locken (för sommaren) skyddar din pool från insekter, damm, löv, ... och undvik att tappa vattentemperaturen. Ställ alltid in den så att bubblorna är i kontakt med vattnet.

VINTER SÄSONG:

A) Om du väljer att inte ta bort poolen:

- 1- Rengör linerns botten och sidor med en icke-slipande produkt.
 - 2- Behandla vattnet med en kemisk produkt för övervintring. Vi rekommenderar att du använder FLYTANDE VINTERISERING istället för att flyta med fast produkt för att undvika missfärgning av linern.
 - 3- Lämna poolen full av vatten med tanke på:
 - a) För pooler med skimmer och påfyllningsrör, sänk vattennivån 5 cm under skimmern och stäng påfyllningsröret med skruvkransen som medföljer filtret.
 - b) För pooler med uttömnings- och påfyllningsrör, minska vattennivån 20 cm från poolens översta kant och stäng rören med det inbyggda skruvsystemet.
 - 4- Koppla loss rören. Demontera inte skimmern och påfyllnings- och uttömningsrören.
 - 5- Skydda poolen med ett vinteröverdrag och lägg ett flytande element mellan locket och vattnet för att skydda den mot frost.
 - 6- Filter: koppla bort det från poolen. Rengör den, töm sanden eller ta bort patronen, torka den och förvara den på en täckt och skyddad från fuktig plats.
 - 7- Tillbehör: ta bort alla tillbehör (steg, larm, strålkastare, pool ...), skölj dem med mjukt vatten och städa bort dem.
- ATT KÖRA BADEN IGEN: Ta bort vinterhöljet, sätt i filtret, byt ut minst 1/3 vatten och gör en klorbehandling. Slå på filtret i minst 8 timmar utan avbrott, med beaktande av den kontinuerliga arbetsperiod som anges i filterhandböckerna.

B) OM DU VÄLJER DEMONTERA POOLEN:

1- Töm poolen. Åtgärder: Filter, automatisk pump för hantering av rent vatten eller kommunicerande fartygssystem. System för kommunikationsfartyg: Använd slang från ditt filter med det minsta tvärsnittet. Fäst en vikt i ena änden och kasta den i poolen. Sänk sedan hela slangen tills det inte finns luft inuti. Stoppa hermetiskt med ena handen under vattnet och ta den till tömningspunkten. Ta bort handen och vattnet börjar rinna. Använd inte detta vatten för att vattna växterna, eftersom det innehåller kemiska produkter.

2- Rengör alla poolbeståndsdelar med en svamp och en tvålprodukt med ett neutralt pH. Torka dem och städa bort dem på en torr och ren plats. Det är normalt att PVC-linern efter att ha installerat och demonterat poolen flera gånger utvidgar och tappar sin elasticitet.

ATT IDRIFSA TÄTTA POOLEN IGEN: Läs en annan gång denna bruksanvisning från början.

KEMISKA ÅTGÄRDER:

Läs noggrant anvisningarna från tillverkaren av kemiska produkter. VARNING: Förvara kemiska produkter på ett rent, torrt och utomordentligt ställe. Viktig: Alla produkter som används måste vara kompatibla med PVC-linern.

- Första fyllningen: Analysera vattnets pH och klor (Cl) och justera dem till de optimala nivåerna: pH: 7,2 - 7,6; Klor: 0,5 - 2 ppm.
- Klorbehandlingar: Fortsätt att öka klornivån tills ungefär 20 ppm för att eliminera bakterier och tång. Denna process måste endast göras när poolvattnet kommer från floder eller dammar ... eller om det stannade länge utan några behandlingar.
- Kontroll: Kontrollera klorhalterna minst en gång i veckan (använd en klor- och pH-analysator). På samma sätt rekommenderar vi att du lägger till en algicid för att förhindra att tång uppträder. Ta aldrig ett dopp innan klornivån stabiliseras. Använd alltid en flytande dispenser för upplösning av kemisk produkt (tabletter). Den kemiska produkten som mäts måste göras i enlighet med: Din poolvattenvolym, badfrekvensen, klimatförhållandena, vattentemperaturen och platsen. Flytta alltid vattnet och vänta på att den kemiska produkten upplöses innan du tillsätter ytterligare ett. Vänta ungefär 12 timmar mellan pH, klor eller algicidjustering med hjälp av filtersystemet.

MEKANISKA ÅTGÄRDER:

Kontrollera att filtret, skummet, ventilerna och rören är väl anslutna till poolen. Tänk på att hög vattentemperatur kommer att innebära mer tid för filtreringen. Teoretisk filtreringstid = Vattenvolym / Filtersystem urladdning (vanligtvis 8 timmar / dag med vattentemperatur 21 ° C), (Idealisk: 2 timmar på morgonen - 4 timmar runt middag - 2 timmar på eftermiddagen). VÄNLIGEN RESPEKTERA DEN KONTINUERLIGA ARBETSTIDEN INDIKERAD I FILTERHANDBOKARNA.

VACUUM CLEANER (MANUAL ELLER AUTOMATISK):

Endast för pooler med skimmer. Anslut en slangänd till borsthuvudet och sänk ner den i vattnet så att den fylls i. Anslut den andra röränden till uttömningsadaptern (TA) och placera den ovanför skumkorgen. Slå på filtret i FILTER-läge och börja rengöra botten. Var särskilt uppmärksam på områden med veck där smuts ansamlas.

BOTTOM RENGÖRING VENTURY STYLE:

Anslut en trädgårdsslang till bottenrenaren och föra in den i poolen. Öppna kranen till ett normalt tryck för att få vattnet att rinna ut mot botten av poolen, vilket ger en stigande ström som lämnar smutsen i filtret (påsen) som justeras på bottenrengöraren

| PROBLEM | ORSAK | LÖSNING |
|---------------------------------------|--|--|
| Grumligt vatten | Dålig filtrering. Hög PH. Organiska rester i överskott | Tvätta filtret. Tillsätt CLARIFIER i tabletter i en dispenser. Utför en chockklorering. |
| Grönt vatten | Bildning av tång eller lera | Borsta försiktigt botten och sidorna på poolen. Analysera PH och justera den mellan 7,2-7,6. Lägg till ALGICID och FLYTANDE CLARIFIER. |
| Brunt vatten | Förekomst av järn eller mangan | Analysera PH och justera den mellan 7,2-7,6. Genomför en CHOCKKLORINATION. Lägg till FLYTANDE CLARIFIER. |
| Inkrustationer | Närvaro av kalkhaltigt i vattnet | Analysera PH och justera den mellan 7,2-7,6. Lägg till ANTI-CALCAREO en gång i veckan. |
| Ögon och hudirritationer. Dålig lukt. | Feljusterad PH. Organiska rester i överskott | Analysera PH och justera den mellan 7,2-7,6. Genomför en CHOCKKLORINATION. |

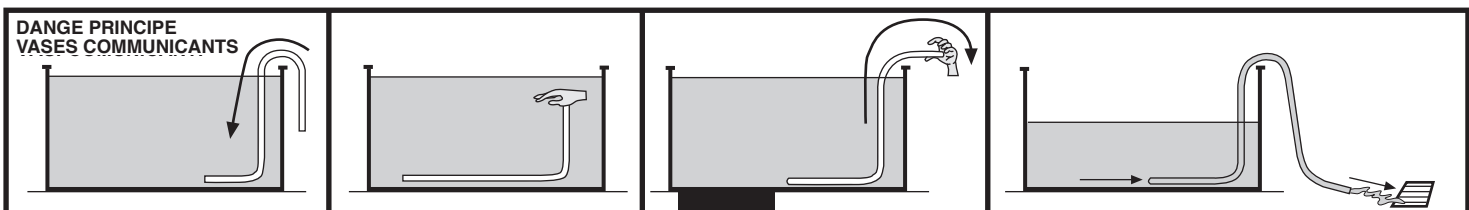



MADE BY – WYPRODUKOWANE PRZEZ - VYROBENO SPOLEČNOSTÍ -
VYROBENÉ SPOLOČNOSŤOU - FABRICAT DE - TILLVERKAD AV:
MANUFACTURAS GRE, S.A. ARITZ BIDEA Nº 57 BELAKO INDUSTRIALDEA,
APARTADO 69 - 48100 MUNGUIA (VIZCAYA) ESPAÑA Nº Reg. Ind. 48-06762
Made in Spain - WYPRODUKOWANO W HISZPANII - VYROBENO VE ŠPANĚLSKU -
VYROBENÉ V ŠPANIELSKU - FABRICAT ÎN SPANIA - TILLVERKAD I SPANIEN